

# **CANAL WILDLIFE FENCING PLAN**

**FERC PROJECT 184**



**April 2007**

**EL DORADO IRRIGATION DISTRICT  
2890 Mosquito Road  
Placerville, CA 95667**

## **Table of Contents**

|   |   |
|---|---|
| I. Introduction.....                        | 1 |
| II. Existing Fence Condition.....           | 2 |
| III. Fence Upgrades and Realignment .....   | 2 |
| IV. Wildlife Mortality Monitoring Plan..... | 4 |
| V. Fence and Crossings Inspection Plan..... | 4 |

## **List of Appendices**

|            |   |
|------------|---|
| Appendix A | Figures   |
| Appendix B | Photo Documentation                               |
| Appendix C | PG&E Wildlife Fencing Specifications and Drawings |

## I. Introduction

According to Condition 43 (Wildlife and Plant Protection Measures) of the U.S. Forest Service (USFS) 4(e) Conditions and section 13 of the El Dorado Relicensing Settlement Agreement, the El Dorado Irrigation District (District) shall maintain and operate in working condition all devices and measures for wildlife along the El Dorado Canal that are deemed necessary by the USFS and California Department of Fish and Game (CDFG) to protect wildlife from the hazards of open canals and other Project facilities. Condition 43 goes on to state that the District shall ensure that all canal crossings and fencings on National Forest System Lands and District adjoining property are maintained in functioning condition. Fencing repairs or replacement necessary to prevent wildlife from entering the canal will be made and maintained in a manner that will continually allow their use by wildlife. In addition, the District shall provide an annual report describing the date, location, and species information (deer or other wildlife) found in the El Dorado Canal to the USFS and the Project 184 Ecological Resources Committee (ERC) by April 1 of each year. Finally, within 6 months of license issuance, the District shall reconstruct those portions of the canal fence and crossing structures that do not meet the height and width specifications provided by CDFG or shall develop a schedule for completing such work that is agreed upon by USFS and CDFG. The District has opted to develop a plan and schedule for fence upgrades and relocation to be approved by USFS and CDFG.

The District has identified its initial priority with inspecting and planning wildlife fencing along Beat One and Beat Two to Camp 2. Beat One is approximately 4.5 miles long, extending between the Diversion Dam and the upstream El Dorado tunnel portal. The Beat Two section, extending approximately 0.5 mile, extends from the downstream Mill-Bull tunnel portal at Bull Creek to Camp 2.

A preliminary investigation of Beat One and Beat Two to Camp 2 wildlife fencing needs was conducted. This included the review of the existing survey of fencing and canal features for Project 184 (EIP 2002) as well as existing Canal Atlas Maps of Project 184 (Price Geographic Consulting 2003). The CDFG Standards for deer fencings outlined in PG&E's Specifications No. DWP11593 (1993) (included herein as Appendix C) were also reviewed.

Fencing, bridges, and crossings were photographed, flagged, and recorded with a GPS unit to identify those sections needing upgrading, relocation and/or repair within Beats One and Two. The sites were also reviewed to determine where vegetation management may be appropriate to satisfy CDFG's request to visually inspect the fence from the canal, without having to relocate fence. Initially, fence relocations will be the primary method used to gain visibility of the canal fencing, not vegetation management as determined by the District, USFS, and CDFG during the June 15, 2005 site visit. Vegetation management will be used for regular fence maintenance.

## **II. Existing Fence Condition**

In 1993, PG&E upgraded 13,300 feet of fence along the canal within Beats One and Two. However, the fence was installed upside down and needs to be flipped to meet CDFG Standards for wildlife fencing. It was determined during the June 15, 2005 site visit with the District, USFS and CDFG that this is not a top priority at this time and can be remedied in the future.

In March 2002, a survey was conducted of the District's deer fence and canal features to document the locations and conditions of deer fencing along the El Dorado Canal (EIP, updated on June 4, 2002). It was found that with the exception of several locations along the canal where fence was damaged, the majority of fencing appeared to be in a functional condition (i.e., effectively excluding deer from portions of the canal).

Currently, fencing downslope and upslope of the canal ranges from 8 feet to over 200 feet from the canal. To meet CDFG's request to be able to visually assess the fence from the canal, it will be moved close enough to be seen from the canal. Lastly, the majority of fence does not meet the specifications of being 8 feet high on the upslope side of the canal and 6 feet high on the downslope side of the canal. This will also be fixed under this Wildlife Fencing Upgrading and Maintenance Plan (Wildlife Fencing Plan).

## **III. Fence Upgrades and Realignment**

Based on a site visit conducted with the District, USFS and CDFG on June 15, 2005, the following areas of fence and necessary upgrades were identified:

- Stub off fence near No Name Creek on either side of natural rock barrier (~800 ft west of existing wildlife crossing) see Appendix A, Figure 5 and Appendix B, Photo 1
- Install new wildlife crossing near area stubbed off (south of canal) – see Appendix A, Figure 5 and Appendix B, Photo 2
- Space posts closer (approximately 4 feet apart) in areas of historic rock slides

Those in attendance at the June 15, 2005 site visit agreed that the District should perform these upgrades/relocations first, then prioritize other areas for relocation or upgrading and vegetation management, and finally 'fix' newer fence by 'flip/flopping' the fence so that the small holes are on the bottom of the fence and the large holes are on the top (see Appendix A, Figures 4 and 5). During the site visit, all parties also agreed that the majority of canal fencing would be relocated along the canal, rather than further away where it exists today, and that Beats One and Two are priority due to the effects of the Cleveland fire and known migratory patterns of deer in the area.

Appendix C provides standards included as part of the PG&E Specification No. DWP11593 for furnishing, fabricating, delivering, and installing deer fencing (dated September 20, 1993). These specifications are required by CDFG for the upgrading and replacement of wildlife fence along the canal. According to the PG&E Specifications:

- Materials used for fence upgrades shall be new, the best of its respective kind, and free from any defects and of the make or quality specified on the drawings of the specifications (Appendix C).
- Where no specific make is indicated, any first-line product of a reputable domestic manufacturer may be used provided it conforms to the requirements of the specifications and meets with the approval of the engineer.
- Similar type material shall be of the same manufacturer throughout the job unless otherwise authorized by the District in writing or otherwise specified in design drawings.

Appendix C also provides material standards in accordance with the American Society for Testing and Materials, which shall be used for upgrading wildlife fencing along the canal.

Figures 1 and 2 in Appendix D show typical canal elevation, wildlife crossings, and fence detail from EIP's June 16, 2003 report as identified in PG&E's Deer Fencing Specifications from 1993.

All existing wildlife crossings along Beats One and Two will be upgraded to provide safer crossings for wildlife in the area, to increase longevity and to reduce maintenance requirements of the crossings.

The District proposes three types of construction as part of the current Wildlife Fencing Plan:

1. **Relocation:** bring fence closer to the canal
2. **Upgrading:** taking existing fence location and bringing fence up to CDFG Standard
3. **Removal:** old fence to be removed and ground rehabilitated as required

In general, wildlife fencing along Beats One and Two needs to be upgraded to meet PG&E Specifications and CDFG Standards and relocated to allow for visual inspections from the canal. Figures 1 through 6 in Appendix A show where fencing would be relocated and upgraded, where natural barriers occur requiring that fencing be 'stubbed off', and where a new wildlife crossing would be constructed. Fencing within Beat One requires approximately 11,165 feet of relocation, 4,355 feet of upgrades (including 10 bridges with about 100 feet of fencing each), and 10,994 feet of old fence removal. Fencing within Beat Two requires approximately 1,595 feet of relocation, 2,005 feet of upgrades (including 3 bridges with about 100 feet of fencing each), and 1,700 feet of old fence removal.

Table 1 identifies the amounts of upgrading, relocation and improved wildlife crossings and proposed schedule for performing these tasks.

**Table 1: Summary of Upgrade, Relocation and Wildlife Crossings**

| Location                             | Task Description                     | Approximate Length (ft) | Map Figure(s) | Scheduled Year* |
|--------------------------------------|--------------------------------------|-------------------------|---------------|-----------------|
| Beat One (near berm)                 | Relocate existing fence              | 5,583                   | 5, 6          | 1               |
| Beat One (near berm)                 | Relocate existing fence              | 5,583                   | 5, 6          | 2               |
| Beat One (upstream of No Name Creek) | Stub off fence                       | N/A                     | 5             | 1               |
| Beat One (near berm)                 | Remove prior fence                   | 5,497                   | 5, 6          | 1               |
| Beat One (near berm)                 | Remove prior fence                   | 5,497                   | 5, 6          | 2               |
| Beat One                             | Install additional wildlife crossing | N/A                     | 5             | 2               |
| Beat One (historic rock slide areas) | Re-space post to approx. 4 ft apart  | N/A                     | 5             | 2               |
| Beat Two                             | Upgrade existing fencing             | 2,005                   | 1, 2, 3, 4    | 3               |
| Beat Two                             | Relocate existing fence              | 1,595                   | 1, 2          | 3               |
| Beat Two                             | Remove prior fence                   | 1,700                   | 1,2           | 3               |
| Beat One (near Flume 4)              | Upgrade existing fencing             | 4,355                   | 5             | 4               |
| Beat One                             | Re-hang existing fence wire          | 10,000                  | 4, 5          | 5               |

\* Year 1 shall be the first spring following plan approval by USFS.

#### **IV. Wildlife Mortality Monitoring Plan**

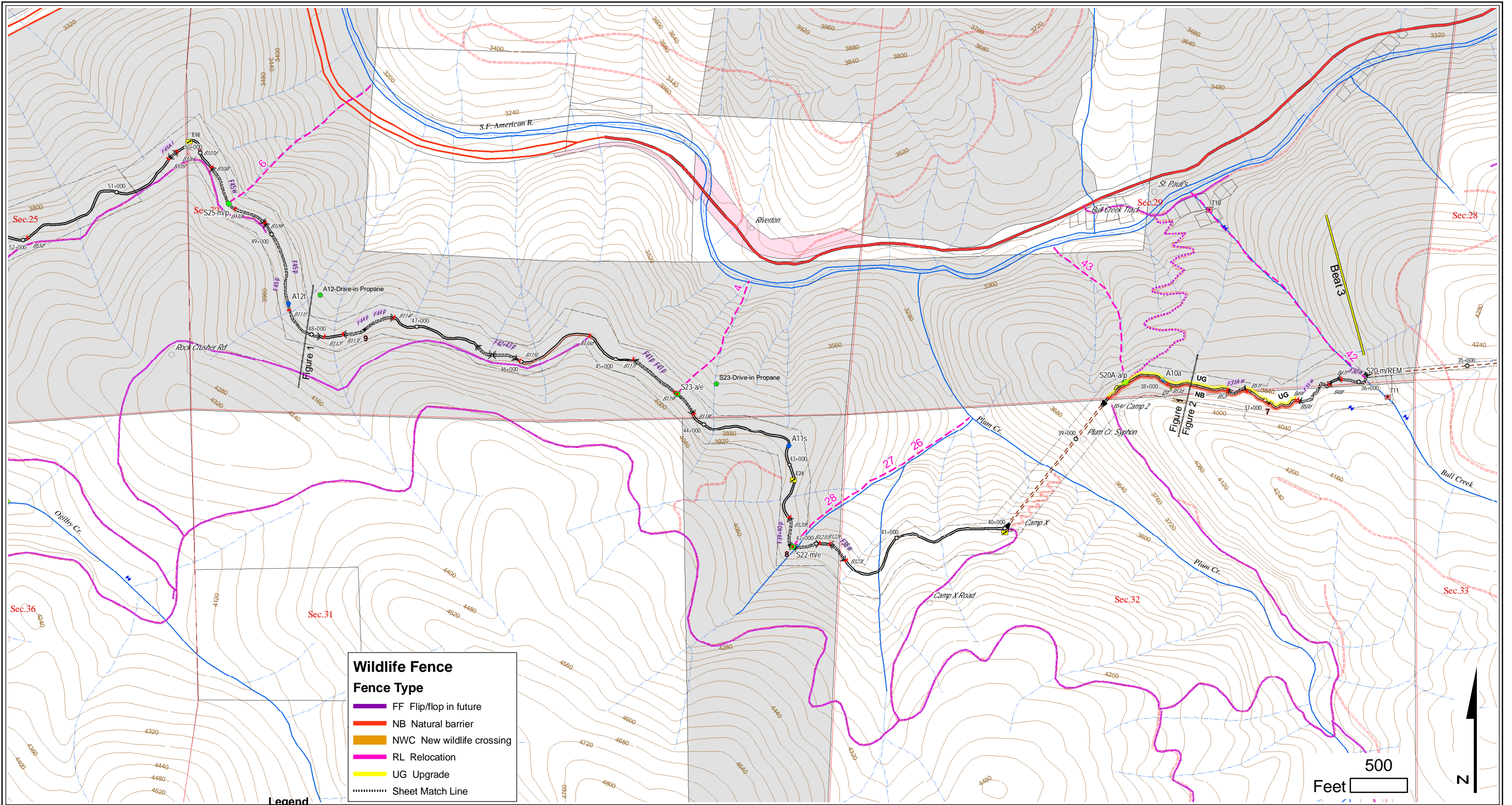
The District currently monitors wildlife mortality on a daily basis as part of canal inspections. Mortality log books are kept at the Alder Creek Siphon, Plum Creek Siphon, Forebay and Ditch Camp 5. According to Condition No. 43 of the USFS 4(e) Conditions, “the licensee [District] shall maintain weekly records of terrestrial wildlife occurrence and mortality in the El Dorado Canal at each of the five Ditch Camps along the canal. The licensee shall provide the USFS and ERC by April 1 of each year an annual report describing the date, location, and species information (deer or other wildlife) found in the El Dorado Canal. In consultation with the agencies listed in Condition No. 45 [USFS, CDFG, and State Water Resources Control Board], the USFS and ERC shall review these data and determine the amount, kind, and location of any additional future fencing at the annual meeting described in Condition No. 45”. Due to past monitoring of deer herds and changes in deer populations, the USFS and CDFG indicated that the start of monitoring with the current Wildlife Fencing Plan will be used as the baseline for mortality records.

#### **V. Fence and Crossings Inspection Plan**

Wildlife fencing and crossing inspections will be conducted semi-annually. Weather permitting the inspections will be conducted prior to spring and winter deer migrations. Based on historical migration patterns, the spring deer migrations are in the last week of April and first week of May with winter migration in the third and fourth week of November. The District will report the results of the inspections at the annual review meeting described in Condition No. 45.

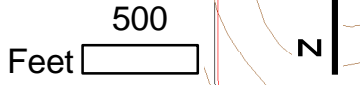
**APPENDIX A**  
**Figures**

M:\EID\_GIS\AndrewPrice\EIDP184-C-Drive\EIDP184-GIS\Canal\_Deer\_Fence\MXD-PDF2006\EID-P184-Canal-Atlas-C-08\Fig1-DF2006.mxd



**Wildlife Fence**  
**Fence Type**

- FF Flip/flop in future
- NB Natural barrier
- NWC New wildlife crossing
- RL Relocation
- UG Upgrade
- ..... Sheet Match Line



Map production and data management by:

**PRICE  
GEOGRAPHIC  
CONSULTING**

2004 Adobe Trail ~ Placerville, California 95667  
 (530) 626-1964 ~ at\_price@pacbell.net

|              |                   |                    |
|--------------|-------------------|--------------------|
| <b>Canal</b> | <b>Spillway</b>   | <b>Equipment</b>   |
| CONCRETE     | Auto, Preferred   | Gauge              |
| FLUME        | Manual, Preferred | Thermograph        |
| NATIVE       | Auto, Emergency   | Bridge             |
| PIPE         | Manual, Emergency | Mile Post Mark     |
| SIPHON       | Spill Channel     | Stationing         |
| TUNNEL       | Alarm             | Ferc-Canal         |
| WOOD         | Deer Escape Ramp  | P184 Access Roads  |
|              |                   | P184 Access Trails |

**Land Ownership**

- Other Lands
- EID Owned Parcels
- State of California
- US Forest Service
- USA
- Bureau of Reclamation
- Sheet Match Line

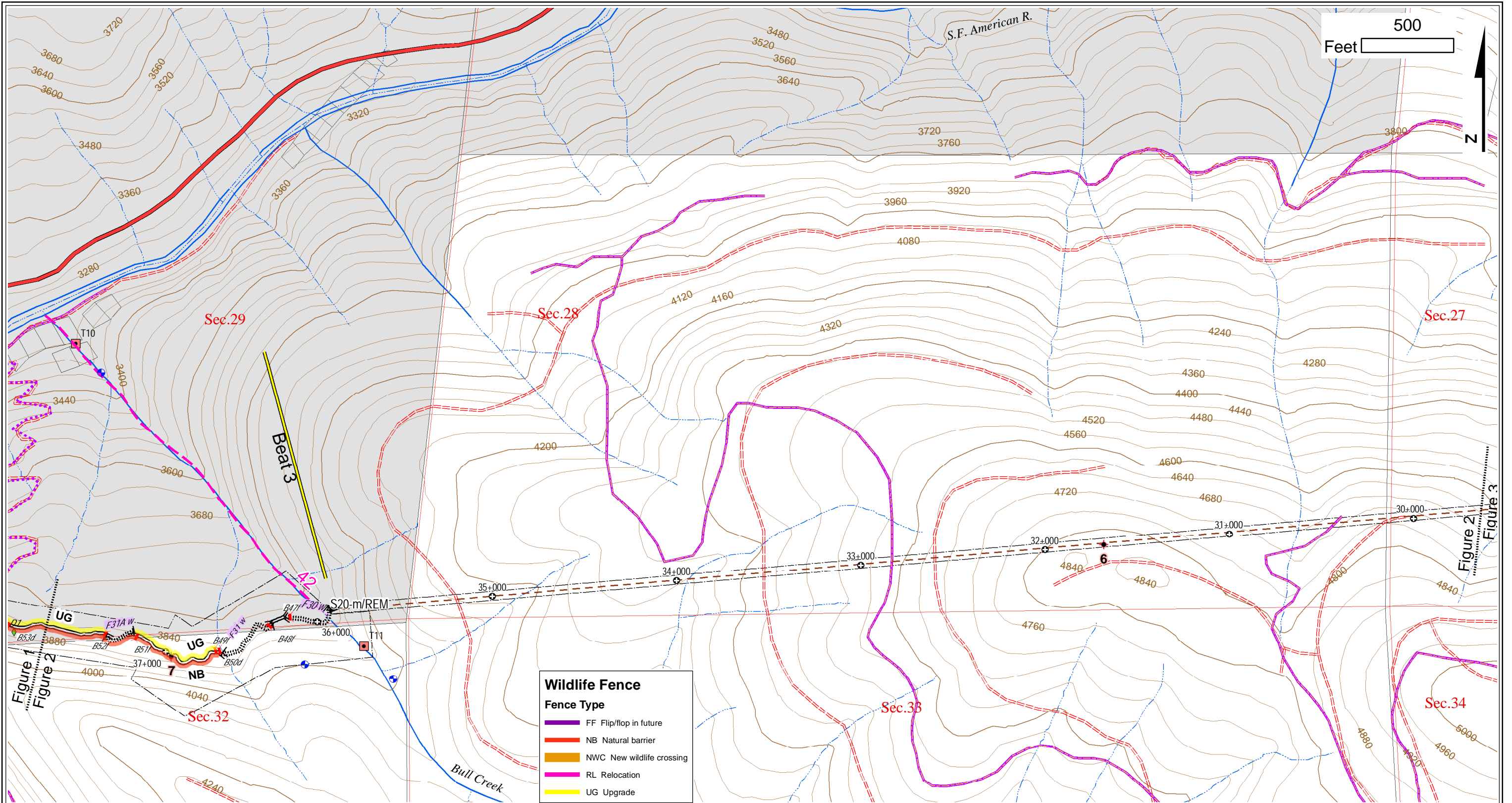
El Dorado Irrigation District  
 2890 Mosquito Road  
 Placerville, Ca 95667  
 (530) 522-4513

**EID Project 184  
El Dorado Canal  
Wildlife Fencing Plan**

Date: Jan 31, 2007 **Figure 1**



M:\EID\_GIS\AndrewPrice\EIDP184-C-Drive\EID-P184-GIS\Canal-Atlas-C-09\Fig2-DF2006.mxd



Map production and data management by:



**PRICE  
GEOGRAPHIC  
CONSULTING**

2004 Adobe Trail ~ Placerville, California 95667  
(530) 626-1964 ~ at\_price@pacbell.net

| Legend |          | Spillway |                   | Equipment |                   | Land Ownership |                       |
|--------|----------|----------|-------------------|-----------|-------------------|----------------|-----------------------|
|        | CONCRETE |          | Auto, Preferred   |           | Equipment         |                | Other Lands           |
|        | FLUME    |          | Manual, Preferred |           | Gauge             |                | EID Owned Parcels     |
|        | NATIVE   |          | Auto, Emergency   |           | Thermograph       |                | State of California   |
|        | PIPE     |          | Manual, Emergency |           | Bridge            |                | US Forest Service     |
|        | SIPHON   |          | Spill Channel     |           | Mile Post Mark    |                | USA                   |
|        | TUNNEL   |          | Alarm             |           | Stationing        |                | Bureau of Reclamation |
|        | WOOD     |          | Deer Escape Ramp  |           | Ferc-Canal        |                |                       |
|        |          |          |                   |           | P184 Access Roads |                |                       |

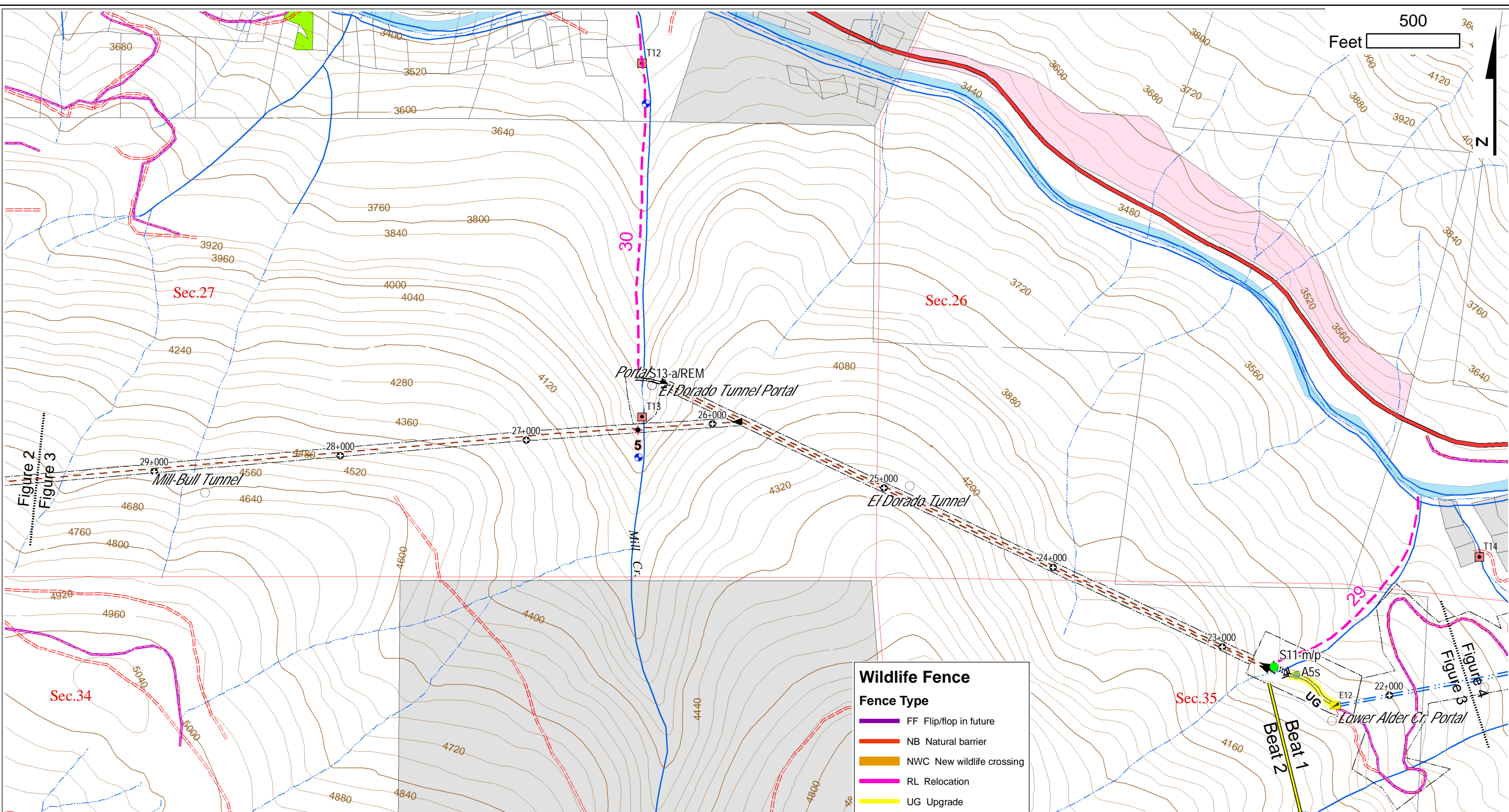


El Dorado Irrigation District  
2890 Mosquito Road  
Placerville, Ca 95667  
(530) 522-4513

**EID Project 184  
El Dorado Canal  
Wildlife Fencing Plan**

Date: Jan 31, 2007 **Figure 2**

M:\EID\_GIS\AndrewPrice\EIDP184-C-Drive\EID-P184-GIS\Canal\_Deer\_Fence\MXD-PDF2006\EID-P184-Canal-Atlas-C-10\Fig3-DF2006.mxd



**Wildlife Fence**

**Fence Type**

- FF Flip/flop in future
- NB Natural barrier
- NWC New wildlife crossing
- RL Relocation
- UG Upgrade

Map production and data management by:



**PRICE  
GEOGRAPHIC  
CONSULTING**

2004 Adobe Trail ~ Placerville, California 95667  
(530) 626-1964 ~ at\_price@pacbell.net

**Legend**

|          |                  |                   |
|----------|------------------|-------------------|
| CONCRETE | Spillway         | Equipment         |
| FLUME    | a, p             | Gauge             |
| NATIVE   | m, p             | Thermograph       |
| PIPE     | a, e             | Bridge            |
| SIPHON   | m, e             | Mile Post Mark    |
| TUNNEL   | Spill Channel    | Stationing        |
| WOOD     | Alarm            | Ferc-Canal        |
|          | Deer Escape Ramp | P184 Access Roads |

**Land Ownership**

- Other Lands
- EID Owned Parcels
- State of California
- US Forest Service
- USA
- Bureau of Reclamation

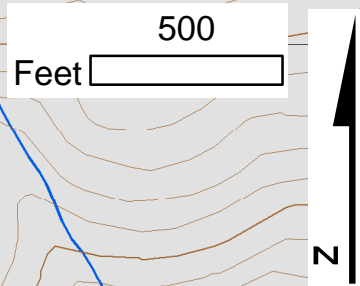
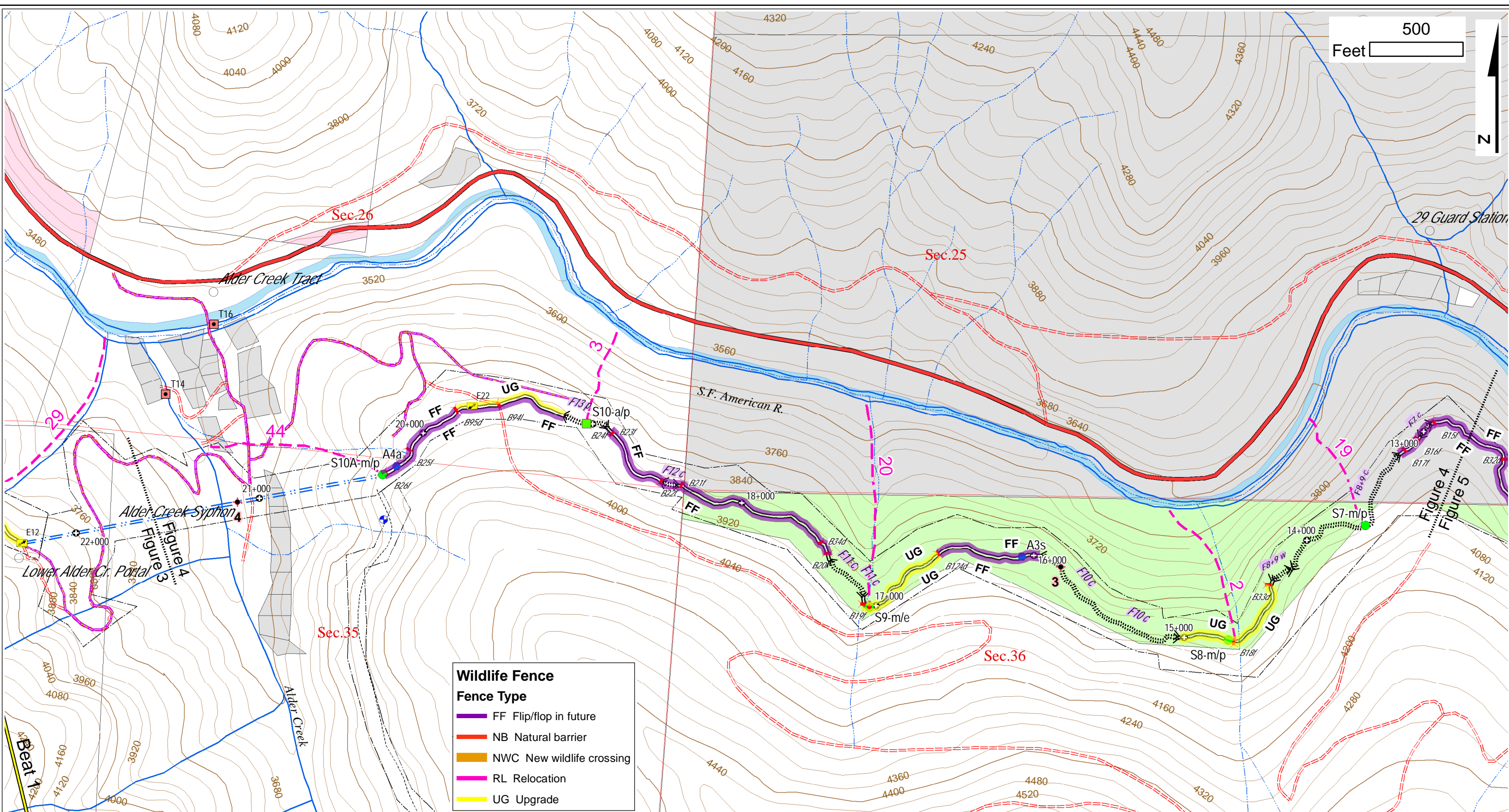


El Dorado Irrigation District  
2890 Mosquito Road  
Placerville, Ca 95667  
(530) 522-4513

**EID Project 184  
El Dorado Canal  
Wildlife Fencing Plan**

Date: Jan 31, 2007 **Figure 3**

M:\EID\_GIS\AndrewPrice\EIDP184-C-Drive\EID-P184-GIS\Canal\_Deer\_Fence\MXD-PDF2006\EID-P184-Atlas-C-11Fig4-DF2006.mxd



**Wildlife Fence**

**Fence Type**

- FF Flip/flop in future
- NB Natural barrier
- NWC New wildlife crossing
- RL Relocation
- UG Upgrade

Map production and data management by:

**PRICE  
GEOGRAPHIC  
CONSULTING**

2004 Adobe Trail ~ Placerville, California 95667  
(530) 626-1964 ~ at\_price@pacbell.net

**Legend**

**Canal**

- CONCRETE
- - - FLUME
- NATIVE
- PIPE
- - - SIPHON
- TUNNEL
- WOOD

**Spillway**

- Auto, Preferred
- Manual, Preferred
- Auto, Emergency
- Manual, Emergency
- Spill Channel
- Alarm
- ◆ Deer Escape Ramp

- Equipment
- Gauge
- Thermograph
- Bridge
- ◆ Mile Post Mark
- Stationing
- Ferc-Canal
- P184 Access Roads

**Land Ownership**

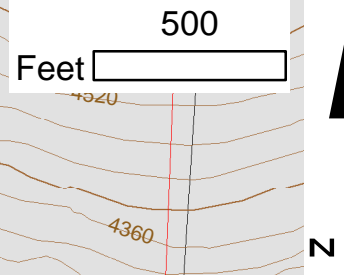
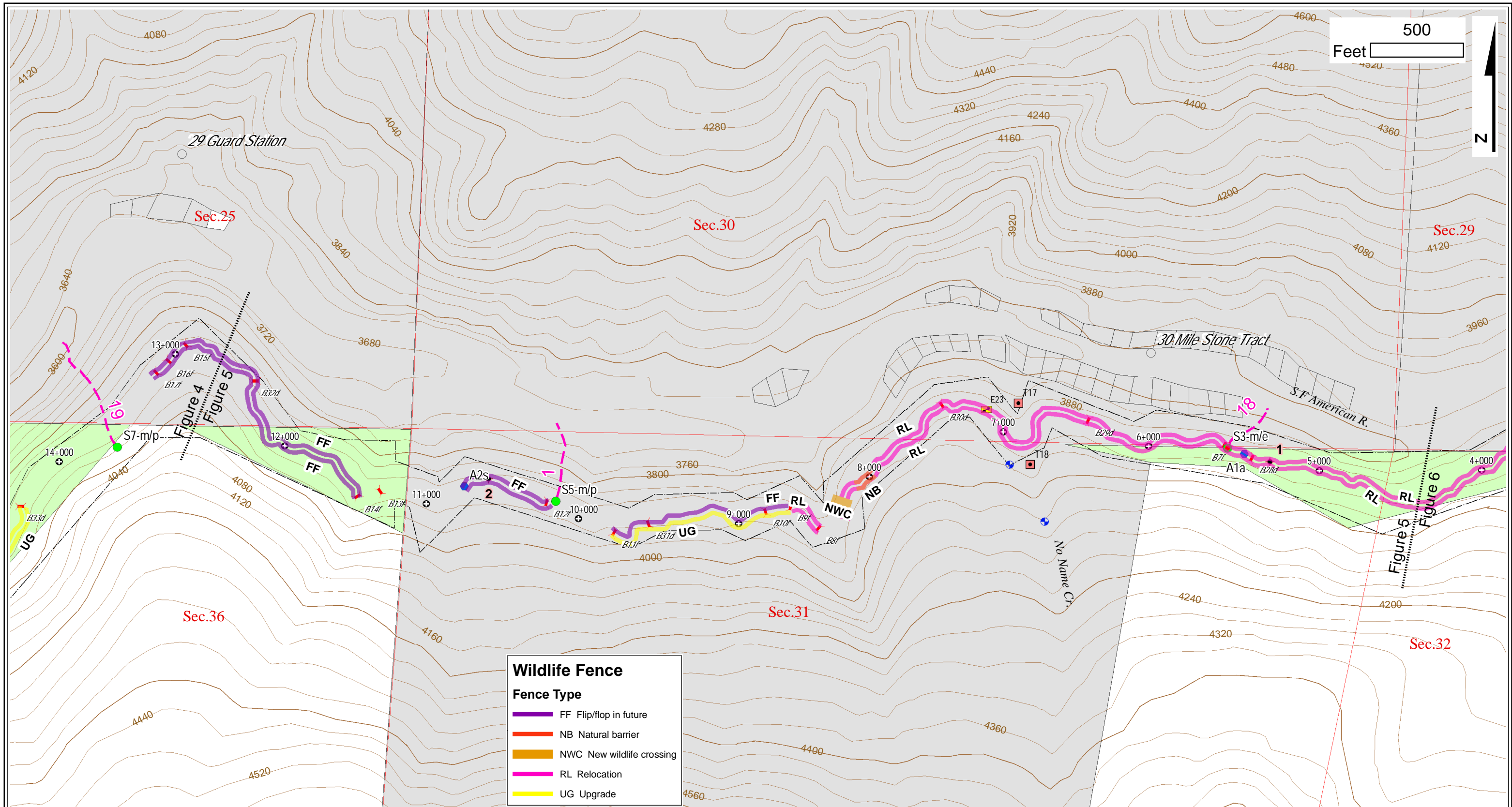
- Other Lands
- EID Owned Parcels
- State of California
- US Forest Service
- USA
- Bureau of Reclamation

**El Dorado Irrigation District**  
2890 Mosquito Road  
Placerville, CA 95667  
(530) 622-4513

**EID Project 184  
El Dorado Canal  
Wildlife Fencing Plan**

Date: Jan 31, 2007 **Figure 4**

M:\EID\_GIS\AndrewPrice\EIDP184-C-Drive\EID-P184-GIS\Canal\_Deer\_Fence\MXD-PDF2006\EID-P184-Canal-Atlas-C-12\Fig5-DF2006.mxd



**Wildlife Fence**

**Fence Type**

- FF Flip/flop in future
- NB Natural barrier
- NWC New wildlife crossing
- RL Relocation
- UG Upgrade

Map production and data management by:

**PRICE GEOGRAPHIC CONSULTING**

2004 Adobe Trail ~ Placerville, California 95667  
(530) 626-1964 ~ at\_price@pacbell.net

**Legend**

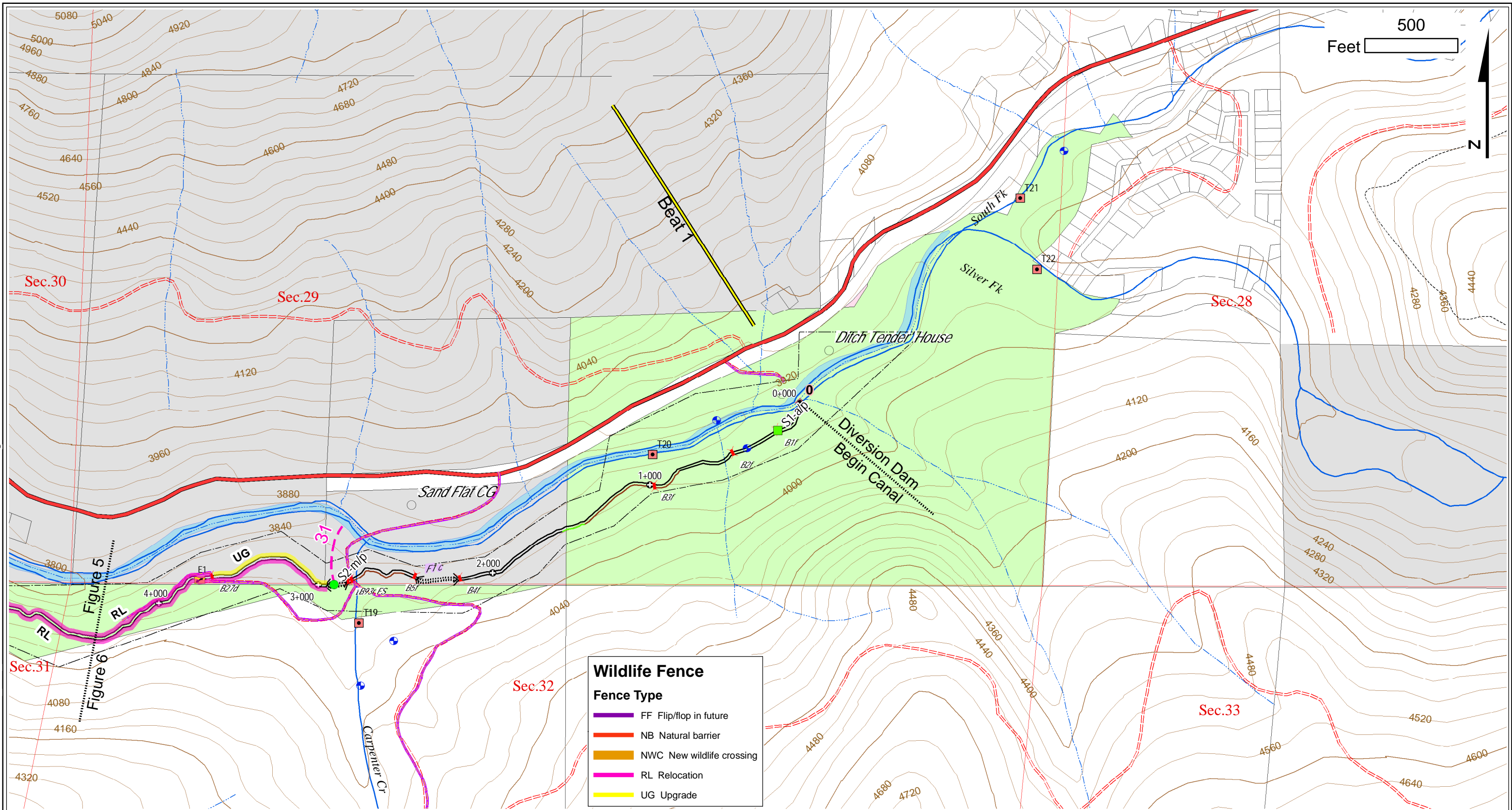
|          |                   |                   |                       |
|----------|-------------------|-------------------|-----------------------|
| CONCRETE | Spillway          | Equipment         | Land Ownership        |
| FLUME    | Auto, Preferred   | Gauge             | Other Lands           |
| NATIVE   | Manual, Preferred | Thermograph       | EID Owned Parcels     |
| PIPE     | Auto, Emergency   | Bridge            | State of California   |
| SIPHON   | Manual, Emergency | Mile Post Mark    | US Forest Service     |
| TUNNEL   | Spill Channel     | Stationing        | USA                   |
| WOOD     | Alarm             | Ferc-Canal        | Bureau of Reclamation |
|          | Deer Escape Ramp  | P184 Access Roads |                       |

El Dorado Irrigation District  
2890 Mosquito Road  
Placerville, Ca 95667  
(530) 522-4513

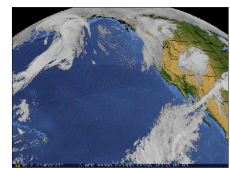
**EID Project 184**  
**El Dorado Canal**  
**Wildlife Fencing Plan**

Date: Jan.31, 2007 **Figure 5**

M:\EID\_GIS\AndrewPrice\EIDP184-C-Drive\EID-P184-GIS\Canal-Atlas-C-13\Fig6-DF2006.mxd



Map production and data management by:



**PRICE  
GEOGRAPHIC  
CONSULTING**

2004 Adobe Trail ~ Placerville, California 95667  
(530) 626-1964 ~ at\_price@pacbell.net

**Legend**

- Canal**
- CONCRETE
  - FLUME
  - NATIVE
  - PIPE
  - SIPHON
  - TUNNEL
  - WOOD

**Spillway**

- Auto, Preferred
- Manual, Preferred
- Auto, Emergency
- Manual, Emergency
- Spill Channel
- Alarm
- Deer Escape Ramp

**Equipment**

- Gauge
- Thermograph
- Bridge
- Mile Post Mark
- Stationing
- Ferc-Canal
- P184 Access Roads

**Land Ownership**

- Other Lands
- EID Owned Parcels
- State of California
- US Forest Service
- USA
- Bureau of Reclamation



El Dorado Irrigation District  
2890 Mosquito Road  
Placerville, Ca 95667  
(530) 522-4513

**EID Project 184  
El Dorado Canal  
Wildlife Fencing Plan**

Date: Jan 31, 2007

**Figure 6**

**APPENDIX B**  
**Photo Documentation**



Photo 1: Stub off fence on either side of natural barrier (downstream of No Name Creek)



Photo 2: New wildlife crossing approximately 300 feet upstream of No Name Creek



Photo 3: Typical fence relocation (looking downstream)



Photo 4: Typical fence relocation (on right) and natural barrier (on left)





Photo 5: Typical fence relocation



Photo 6: Typical fence relocation



Photo 7: Typical fence relocation (looking upstream)



Photo 8: Typical fence upgrade (looking upstream)



Photo 9: 1993 PG&E fence upgrade (looking downstream)



Photo 10: Typical fence upgrade (looking upstream)

**APPENDIX C**  
**Fencing Specifications and Drawings**

# PG&E Wildlife Fencing Specifications

The following information is an excerpt from the PG&E Specification No. DWP11593, dated September 20, 1993, developed for wildlife fencing on the El Dorado Canal.

## **MATERIAL REQUIREMENTS:**

Materials furnished hereunder shall be new, the best of its respective kind, free from defects, or of the make or quality specified on the drawings of this specification.

Where no specific make is indicated, any first-line product of a reputable domestic manufacturer may be used provided it conforms to the requirements of this specification and meets with the approval of the engineer.

Similar type material shall be of the same manufacturer throughout the job unless otherwise authorized by PG&E in writing or otherwise specified in design drawings.

## **1. EXTENT OF WORK:**

**1.1 GENERAL:** Work under this section comprises furnishing, fabricating and delivery, and installation of deer fencing as specified herein and as shown on the drawings of this specification. Material shall include, but not be limited to, wire mesh, post, bracing, gates, fasteners, and connection hardware.

**1.2 GOVERNING REQUIREMENTS:** Work shall comply with the applicable provisions of the ASTM Standards referenced in section 2.1, except where otherwise specified herein and except for requirements which obviously do not relate to work hereunder.

**1.3 QUALITY ASSURANCE AND QUALITY CONTROL:** As specified in this section and in section 1.

**1.4 SHOP DRAWINGS:** Shop drawings shall be submitted as required in paragraph 4 of section 1 of this specification.

## **2. REFERENCES**

The following standards are part of this specification. The supplier shall be responsible for providing materials in accordance with these standards unless otherwise noted. Reference standards including their date of adoption or revision are as follows and will be referred hereinafter by their abbreviations:

### **2.1 ASTM American Society of Testing and Materials**

**A36-89** Specification for Structural Steel

**A53-90** Specification for Pipe, Steel Black and Hot Dipped, Zinc-coated (Galvanized), Welded and Seamless for ordinary uses

**A116-88** Specification for Zinc-Coated (Galvanized) Steel Woven Wire Fence Fabric

**A121-92a** Specification for Zinc-Coated (Galvanized) Steel Barbed Wire

**A123, A-89** Specification for Zinc (Hot-Galvanized) Coatings on Products Fabricated from Rolled, Pressed, and Forged Steel Shapes, Plates, Bars and Strip (Rev A-89)

**A239-89** Test for Locating the Thinnest Spot in a Zinc (Galvanized) Coating on Iron or Steel Articles by the Preece Test (Copper Sulfate Dip)

**A702-89** Specification for Steel Fence Posts and Assemblies, Hot Wrought

**B633-85** Specification for Electrodeposited Coating of Zinc on Iron and Steel

**F626-91** Standard Specifications for Fence Fittings

**F669-92** Standard Specification for Strength Requirements of Metal Posts and Rails for Industrial Chain Link Fence

**F1083-91** Standard Specification for Pipe, Steel, Hot-Dipped Zinc-Coated (Galvanized) Welded, for Fence Structures

**F1234-92** Standard Specification for Protective Coatings on Steel Framework for Fences

### 3. MATERIAL

**3.1 GENERAL:** Material shall be free from shop defects. Defective material, material not up to the required gage (standard variations being allowed), or material that develops defects incidental to fabrication or erection will be rejected, notwithstanding that the same may have satisfactorily passed previous tests. Material shall be new and of first quality.

**3.2 GALVANIZING:** Metal fence posts, braces, rails and gate material shall be galvanized and shall be tested in accordance with ASTM A239. Galvanizing of other fabric shall conform to ASTM A123. Abraded galvanized areas shall be touched up after erecting with Sprayon "740 Galvanizing Compound" or CRC "Zinc-it" (aerosols), or approved equivalent.

**3.3 DEER FENCING FABRIC:** Fabric shall conform to ASTM 116-88, 14 gage, class 1 zinc-coated (galvanized) wire. Height of fabric shall be 72 inches, with graduated line wire spacing, with the largest spacings placed on top and the smallest spacing on bottom.

**3.4 CHAIN LINK FABRIC:** Fabric shall conform to ASTM A491, 9 gage aluminized wire, 2" mesh, knuckled at top selvage and twisted and barbed at the bottom. Height of fabric shall be as shown on drawings.

**3.5 BARBLESS BARBED WIRE:** Barbless barbed wire shall conform to ASTM A121-92a, 2 strand, 12 1/2 gage, class 3 zinc-coating.

**3.6 TENSION AND TIE WIRE:** Tension and tie wires shall conform to ASTM A116-88, class 3 zinc-coated (galvanized) wire, and shall be 11 gage, or heavier.

**3.7 POSTS, GATE FRAMES, BRACES, RAILS AND FITTINGS:** Posts, gate frames, braces, rails, and fittings shall comply with the diameters and schedules shown on the drawing and shall conform to ASTM A702-89 (Posts) and ASTM F626-91 (Fence Fittings). All pipe posts shall be capped. If a conflict exists between the ASTM Specifications and the drawing, the heavier gage or zinc-coating shall govern.

**3.8 MISCELLANEOUS MATERIALS:** Galvanized bolts and nuts for attaching braces and straps to metal posts and suitable galvanized hardware, as required, shall be of commercial quality and design.

**3.9 REPORTS:** If required by engineer, supplier shall furnish four certified copies of the reports on chemical analysis and physical tests as described in the referenced specifications and standards.

**3.10 ALL** other steel shall be ASTM A36.

**3.11 CONCRETE:** Concrete for setting fence posts, where required, shall be proportioned with 3/4" maximum size aggregate, contain not less than 470 pounds of cement per cubic yard, and provide a 28-day compressive strength of 3000 psi. Concrete shall be in place a minimum of 10 days before tension is applied to the fence posts.

#### **4. FABRICATION AND ERECTION:**

**4.1 GENERAL:** Fabrication and erection of the fencing and gates shall be performed by personnel experienced in this type of work. Finished installation shall be representative of the best workmanship of the trade. See drawing for additional information.

**4.2 FABRICATION:** Details and fabrication shall conform to referenced ASTM Standards.

#### **4.3 ERECTION:**

**4.3.1 POST HOLES:** Post holes shall be plumb and in true alignment. Bottoms of the holes shall be approximately flat and not less than 3 inches below the bottom of the posts. Earth or rock removed from post holes shall be spread out and distributed around the work site.

**4.3.2 DRIVEN POSTS:** Posts set by driving shall be driven to a minimum depth of 18 inches, or as required to bury the base plate of the post, or obtain a firm, stable mount for the wire mesh. Any post that is bent, has a detached base plate, or is damaged in any other way during installation shall be replaced.

**4.3.3 POST SETTING:** Line posts shall be placed at no more than 10 foot centers in the line of the fence, and set in place by driving, in accordance with paragraph 4.3.2 of this section. Gate posts shall be installed where shown on the

drawings, except that the posts shall be set to provide sufficient clearance for gate hardware and gates. Pull posts shall be installed at any point where the line of the fence changes direction by 15° or more. Gateposts and braced posts shall be concreted in place. Prior to pouring concrete, postholes shall be wetted to provide moisture for curing the concrete. However, no standing water shall be allowed to remain in the hole when concrete is placed. Concrete shall be thoroughly compacted when being placed. Posts shall be set in holes filled with concrete. Exposed top surface of the concrete shall be steel troweled to a slope to provide a neat appearance and to shed water. Posts shall be plumb and accurately aligned.

**4.3.4 TRUSS RODS:** A steel truss rod not less than 3/8-inch diameter fitted with a turnbuckle (or approved equivalent adjustment hardware), shall extend from the line post end of the brace to the base of the gate, corner, pull, or end post and securely fastened to both posts.

**4.3.5 TENSION WIRE:** Top and bottom tension wires of the wire mesh shall be fastened to the line posts with clips or wire ties and shall be continuous and taut from one end to the other on each stretch of fence. Tension wires shall be securely fastened to each gate, corner, pull, and end post.

**4.3.6 FABRIC:** Deer fencing fabric shall be installed on the outside of the posts and shall be evenly stretched and fastened to posts and braces by means of bands or tie wires with a minimum of 8 ties per post, or as required to stabilize wire fabric. Chain link fabric shall be similarly applied and attached at all gates.

**4.3.7 BARBLESS BARBED WIRE:** Two strands of barbless barbed wire shall be secured to the posts. Wire shall be continuous from end to end of each stretch of fence, be drawn taut, and securely fastened to the gate, corner, pull, and end posts.

**4.3.8 GATES:** Gates shall be erected plumb and true, complete with necessary accessories properly installed to provide smooth operation.

**4.3.8.1** Gate frames shall be constructed of not less than 1-7/8 inch, schedule 40 pipe. Gate frame panels shall be cross trussed with 3/8 inch adjustable truss rods. The corners of the gate frames shall be fastened together and reinforced with a malleable iron or a pressed steel fitting designed for the purpose, or by welding. Pressed steel fittings shall have a nominal thickness, before galvanizing, of not less than 0.135 inch and shall be fastened suitably to develop the strength of the connected members. Welding shall conform to the best commercial practices; all welds shall be sound and shall develop the strength of the connected member. All welds shall be smooth.

**4.3.8.2** All fittings, latches, rods, and other gate hardware shall be galvanized in accordance with the provisions of paragraph 3.2 of section 2 of this specification.

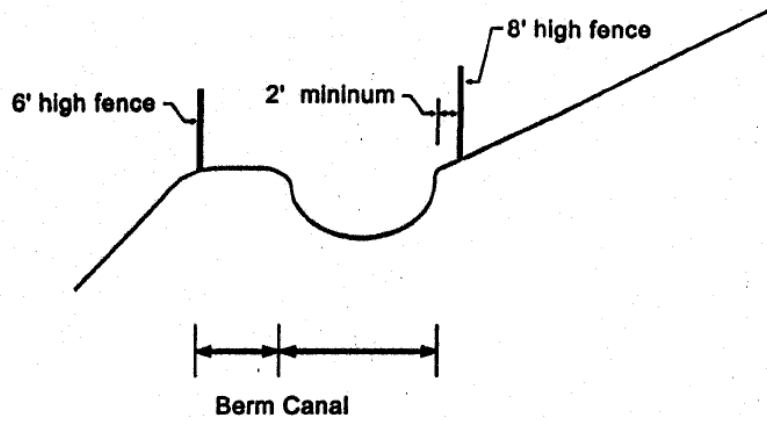
**4.3.8.3** Chain link fence fabric specified for the fence will be attached to the gate frame by the use of stretcher bars and tie wires as specified for fence construction, and suitable tension connectors shall be spaced at approximately one foot intervals.



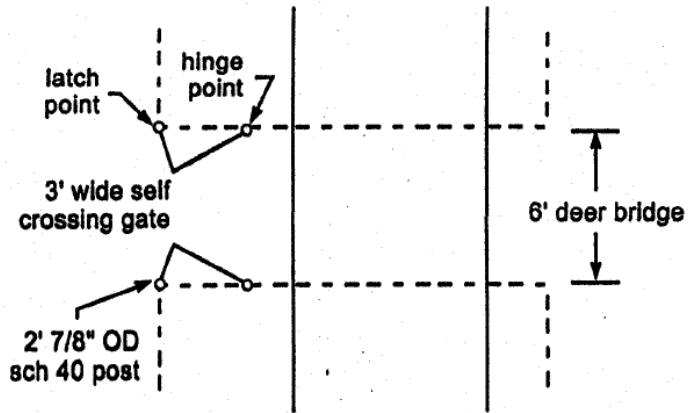
**4.3.8.4** The gates shall be hung by at least 2 steel or malleable iron hinges, not less than 3 inches in width, so designed as to securely clamp to the gate post and permit the gate to swing 180°, with heavy duty, commercial grade, self-closing hardware.

- 4.4** In general, in determining the post spacing, measurements shall be made parallel to the ground slope, and all posts shall be placed in a vertical position, except in unusual locations where directed by the engineer, the posts shall be set perpendicular to the ground surface.
- 4.5** Any high points which interfere with the placing of wire mesh shall be excavated to provide and ensure that the required height of fencing is maintained.
- 4.6** Damaged galvanizing of the fence and appurtenances shall be repaired by applying a coat of Sprayon “740 Galvanizing Compound”, CRC “Zinc-It”, or approved equivalent to the damaged area.

# Typical Canal Elevation, Deer Crossing & Fence Details



TYPICAL CANAL ELEVATION



DEER CROSSING

Not to Scale

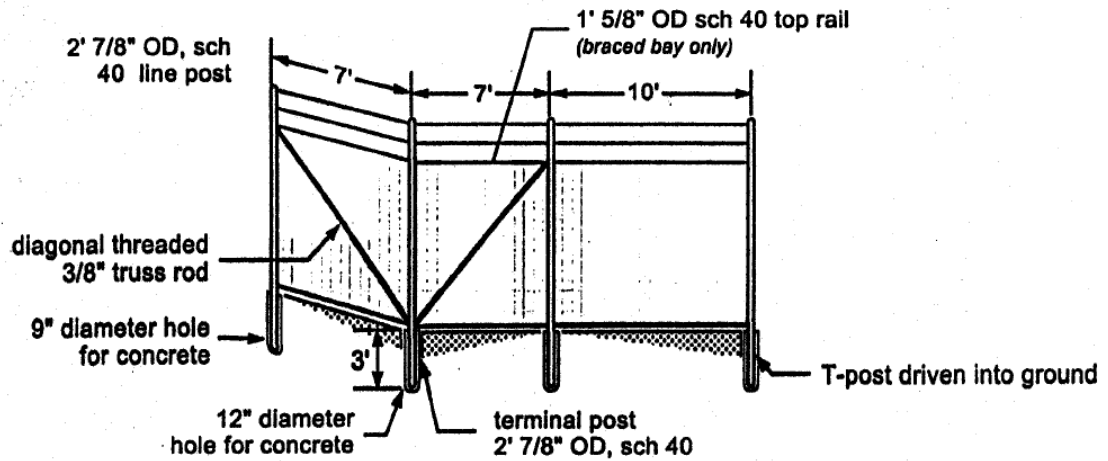
SOURCE: Pacific Gas & Electric Co. 1993

10540-01

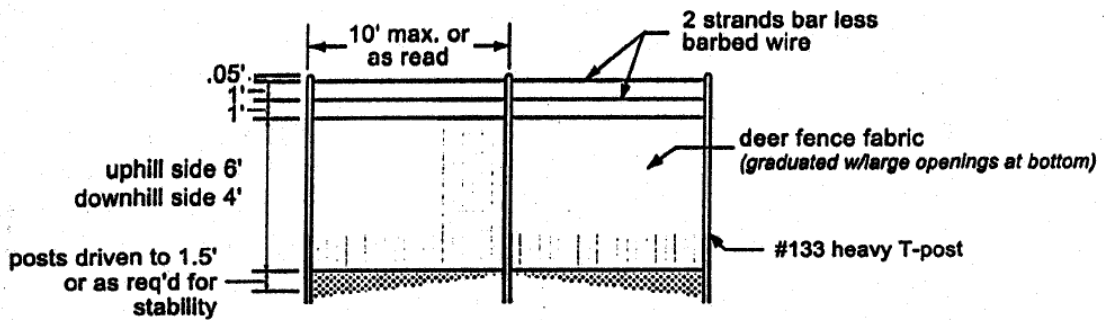


FIGURE 1  
Preliminary Design Drawing

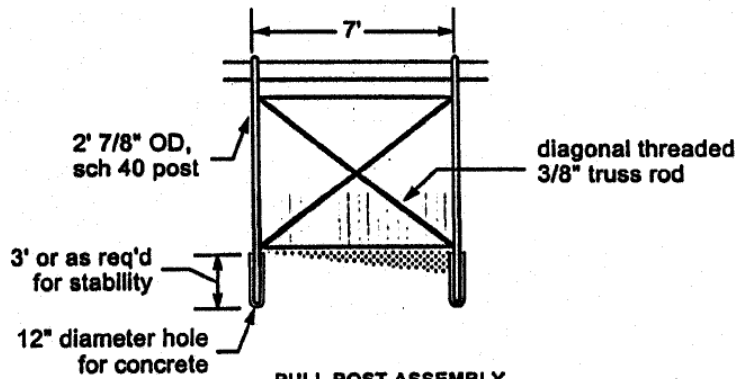
El Dorado Canal



**END AND CORNER POST ASSEMBLY**



**TYPICAL FENCE DETAIL**



**PULL POST ASSEMBLY**  
(@ 660' max. between unbraced sections)

Not to Scale

SOURCE: Pacific Gas & Electric Co. 1993

10940-01



**FIGURE 2**  
**Preliminary Design Drawing**

El Dorado Canal

FEDERAL ENERGY REGULATORY COMMISSION  
Washington, D. C. 20426

OFFICE OF ENERGY PROJECTS

Project No. 184-118—California  
El Dorado Project  
El Dorado Irrigation District

AUG 08 2007

Ms. Cheri Jagers  
El Dorado Irrigation District  
2890 Mosquito Road  
Placerville, CA 95667

RE: Canal Wildlife Fencing Plan pursuant to Appendix A Condition 43.1.b.

Dear Ms. Jagers:

This is in reference to the material you filed on April 17, 2007, to comply with the U.S. Forest Services' (FS) Condition 43.1.b contained in Appendix A of the Order Issuing New License for the El Dorado Project. Condition 43.1.b requires you to reconstruct those portions of the canal fence and crossing structures that do not meet the height and width specifications provided by the California Department of Fish and Game (CDFG), or develop a schedule for completing such work that is agreed upon by the FS and CDFG.

Your April 17 filing includes a description of existing fence conditions, a schedule and proposal for fence upgrades and realignment, a wildlife mortality monitoring plan, and a fence and crossing inspection plan. The filed plan includes letters from the FS and CDFG documenting their concurrence with the plan.

The filed material satisfies the requirements of Condition 43.1.b. If you have any questions concerning this matter, please call me at (202) 502-6012.

Sincerely,



Rebecca M. Martin  
Environmental Biologist  
Division of Hydropower  
Administration and Compliance