

EL DORADO HYDROELECTRIC PROJECT

FERC PROJECT NO. 184

OYSTER CREEK STABILIZATION PLAN

Prepared by:

Horizon Water and Environment

Oakland, California

Prepared for:



El Dorado Irrigation District
2890 Mosquito Road
Placerville, CA 95667

REVISED April 2012

INTRODUCTION

The Oyster Creek Stabilization Plan (Plan) is a requirement of the El Dorado Hydroelectric Project (Project 184) October 18, 2006 Federal Energy Regulatory Commission (FERC) license. The El Dorado Irrigation District (District) prepared the Plan, dated January 2010, to meet the project objectives of “stabilizing the Oyster Creek channel banks to accommodate leakage flows from Silver Lake, while minimizing the contribution of fine sediment to the downstream aquatic habitat, and maintaining a healthy riparian ecosystem.” Based on comments received from the United States Forest Service (USFS), the District prepared this revised Plan, which minimizes temporary and permanent construction impacts related to the heavy civil work needed to implement the original Plan, while still achieving the project objectives.

This revised Plan is subject to approval by the USFS pursuant to Section 4(e) Condition No. 35 and the California State Water Resources Control Board (SWRCB) pursuant to Condition 6 of the 401 Water Quality Certification. The SWRCB approved the original Plan on January 14, 2010. The District will seek input from the SWRCB on this revised Plan to determine whether any subsequent SWRCB approval is necessary. Following approval by USFS and SWRCB, the Stabilization Plan is subject to FERC approval pursuant to Article 401 of the Project 184 license.

STABILIZATION PLAN

This revised Plan has been developed to minimize temporary and permanent construction related impacts. This Plan is informed by 5 consecutive years (2007-2012) of direct site observations made during field inspections and constructability reviews at the project site. The Plan is also informed by a geomorphic data record of the project site that spans a 10-year period (1999-2009). The most recent field inspection was conducted in August 2011 (Attachment B; Blue Line Consulting, 2011). This inspection followed the 2011 spring/summer runoff season, which was characterized as a Wet year according to Project 184 license criteria. Field observations indicate that the 2011 spring/summer runoff did not cause significant erosion in the mainstem of Oyster Creek or the North Tributary. These observations, along with previous field investigations, suggest that Oyster Creek is on a trajectory toward recovery from impacts associated with seepage from Silver Lake Dam and non-Project 184 related factors such as State Route 88 and grazing. A constructability review was conducted at the project site in January 2012 and site photographs are provided in Attachment A.

Due to these recent observations, we concur with the USFS to employ a stabilization approach which minimizes construction-related disturbance and accordingly propose utilizing biotechnical stabilization techniques to achieve the project objectives identified in the Plan. These techniques can be implemented primarily with hand labor, do not impose significant ground disturbance, and carry minimal risk of undesirable outcomes. The components of the revised Plan are described in the following sections. Drawings depicting the revised Plan are provided in Attachment C.

North Tributary Stabilization

Potentially unstable, erosion features in the North Tributary, located primarily on private property, include the main headcut in the gullied section of the channel (Photo 1), and a few small drainages that feed into the North Tributary from the adjacent meadow (Photo 2). Erosion at the main headcut appears to be controlled by a bedrock outcrop and/or roots of woody vegetation. This headcut has not shown significant headward advance since monitoring began in 2007, but it is potentially vulnerable to erosion through flanking or scour. Small drainages that convey surface flow and groundwater discharge from the adjacent wet meadow to the gullied portion of the North Tributary are also eroding at a relatively slow rate. Continued erosion of these drainages could alter the ecological functions and values of the meadow because it could result in desiccation of adjacent areas and a corresponding shift in plant community composition. Stabilization in the North Tributary focuses on controlling erosion at these locations.

Sheet C3 of Attachment C shows the proposed biotechnical stabilization treatments for the North Tributary. The proposed biotechnical treatments will utilize live woody cuttings, dead wood and brush, a small amount of rock, and biodegradable erosion control products (i.e., coir fabric and rolls). The live woody cuttings and dead wood will be collected on-site (See Photos 3 and 4); rock and biodegradable erosion control products will be imported to the site.

At the main headcut, a live “brush pack” treatment will be used to control erosion, provide energy dissipation, and trap sediment. The brush pack will consist of logs, branches, live cuttings, and graded stone (rock). These materials will be placed in lifts at the face of the headcut (See Sheet C5 of Attachment C). If available, native soil will be placed in the brush pack to fill the voids between stones and logs. It is anticipated that the cuttings will establish and the wood will decompose, leaving a dense thicket of woody vegetation in the vicinity of the headcut. An apron of launchable rock will be placed in the channel directly upstream of the headcut. If the headcut migrates upstream, the rock will fall (or launch) into the brush pack, thereby filling voids and dissipating energy. A biodegradable coir log will be placed at the downstream end of the brush pack. The coir log will trap sediment that may erode from the headcut and will act to “backwater” the headcut, thereby promoting deposition of sediment. Over time, sediment stored behind the coir log will be stabilized by natural recruitment of woody and herbaceous vegetation.

Live fascines will be used to stabilize two small gullies that enter the North Tributary (Sheet C3 of Attachment C). Live fascines consist of bundles of woody cuttings placed parallel and perpendicular to the direction of flow. These measures will establish preferential drainage pathways, and increase bed resistance and roughness. This treatment will reduce the potential for further scour and will trap sediment delivered from upstream areas.

The entire North Tributary stabilization area will be planted with willow cuttings (5 ft on-center) to increase roughness and improve sediment storage potential. Temporary browse protection tubes will be placed on 50% of the willow cuttings to protect from herbivory.

Work in this area would be facilitated by a small piece of equipment such as a personal ATV with trailer and/or skid-steer. The equipment would access the North Tributary via an existing road on private property which skirts the meadow (Sheet C2 of Attachment C).

Oyster Creek Bank Stabilization

Overall, the mainstem Oyster Creek is on a trajectory to recover, but there remain isolated areas of instability, hence the need for active restoration/stabilization. Active bank erosion is occurring between River Station (RS) 37+00 and 40+00 (See photolog in Attachment A). Erosion at this location is caused by toe scour and groundwater sapping (Blue Line Consulting, 2009). Although erosion rates are relatively slow, this appears to be the most unstable portion of the Oyster Creek channel. Sheet C4 of Attachment C shows the proposed biotechnical stabilization treatments for this area. The proposed treatment includes installing a biodegradable coir roll and planting live woody cuttings. The coir roll will be installed near the toe of the bank; the precise elevation will be determined in the field. Woody cuttings (willow and alder) will be planted on the eroding bank upslope from the coir roll. Woody cuttings develop dense, deep root systems that help protect banks from erosion. Woody vegetation also increases roughness, which reduces streamflow velocity and helps trap sediment. Woody vegetation planting will improve aquatic habitat by providing additional shade and cover; increasing hydraulic complexity and bank resistance, which can induce the formation of scour pools; and increasing organic matter inputs, which is important for macroinvertebrate production.

The left bank in the vicinity of RS 47+50 is tall (approximately 10 feet) and near vertical. Active erosion has not been observed at this location since monitoring began in 2007 (See photolog in Attachment A). It appears that this section of the channel has developed adequate cross-sectional area to minimize bank erosion caused by scour. The previous version of the Stabilization Plan called for removing trees from the top of bank and positioning them near the toe of slope to redirect flows and reduce the potential for scour. This stabilization measure is not recommended at this time because the bank has not showed signs of significant erosion, and removal of trees from the top of bank has the potential to destabilize it. This revised approach is now consistent with minimizing construction related impacts which would have occurred under the original Plan since a road would have had to been constructed through the meadow to bring in the heavy equipment necessary to conduct this work.

MATERIALS & SCHEDULE

To the extent practicable, materials used in the revised Plan will be collected on-site on both private and USFS property in coordination with the private landowner and the USFS. Biodegradable erosion control products (e.g. coir rolls, blankets) and a small amount of rock (approximately 10-15 cubic yards) will be imported to the site. All woody cuttings for live planting will be harvested locally and planted while dormant. The project will be implemented in late fall or early spring, depending on site and weather conditions. If implemented in early spring, then the cuttings will be collected during the preceding winter (February –March), then

placed in cold storage until the ground temperature is suitable for planting (~50°F). If implemented in the late fall, cuttings will be collected when woody shrubs have dropped their leaves (late October- November), then planted immediately. Work that is not dependent on the use of woody cuttings (e.g. placement of erosion control products or rock) may be conducted after August 1. The on-site project work is estimated to take 10 - 20 days to complete.

PROJECT REVIEW AND APPROVAL

EID will consult with various regulatory agencies to obtain approvals and permits that may be necessary to conduct this work including, but not limited to:

- California Department of Fish and Game Streambed Alteration Agreement
- Army Corps of Engineers Section 404 Nationwide Permit
- Regional Water Quality Control Board Section 401 Water Quality Certification
- USFS approval for activities on USFS lands
- Federal Energy Regulatory Commission

Components of the project that take place on private property (e.g., North Tributary stabilization) will need to be approved by the property owner. If the District is unable to receive approval from the landowner to implement the plan in its current state, the District will work with the private landowner to revise the plan so that it is acceptable to the landowner, SWRCB, and USFS. If for some reason a significant revision is required that necessitates a modification, then the District will seek approvals of the modification.

POST-PROJECT MONITORING

The stabilization measures presented in this revised plan are designed to reduce erosion rates and expedite channel stabilization in the Oyster Creek system. Following implementation of the revised plan, the District will monitor the Oyster Creek channel and the success of stabilization measures included in this Plan as a component of USFS 4(e) Condition 37 and SWRCB Condition 13.h, *Geomorphology (Continuing Evaluation of Representative Channel Areas)* monitoring efforts, which requires geomorphic monitoring of representative channel areas throughout the term of the Project 184 license. The District began implementing this plan in 2011. Additionally, it is anticipated that maintenance requirements for physical, vegetative, and structural components of the revised Plan will be developed through the regulatory permitting processes identified above.

REFERENCES

Blue Line Consulting. 2009. Oyster Creek Sensitive Site Monitoring Report. Prepared for El Dorado Irrigation District. August.

Blue Line Consulting. 2011. Oyster Creek Stabilization Plan: Observations from August 2011 Field Inspection. August.

ATTACHMENT A

**Site Photographs
January 2012**



Photo 1. Main headcut in North Tributary



Photo 2. Small drainage feeding into North Tributary



Photo 3. Example of dead wood to be collected for use in brush pack treatment.



Photo 4. Example of dead wood to be collected for use in brush pack treatment.

ATTACHMENT B

**Oyster Creek Stabilization Plan
Observations from August 2011 Field Inspection**



Project: Oyster Creek Stabilization Plan August 31, 2011

To: Jake Eymann, Brian Deason, Dan Corcoran; El Dorado Irrigation District

From: Kevin Fisher; Blue Line Consulting

Subject: Observations from August 2011 Field Inspection

This memorandum documents the findings of a field inspection conducted at Oyster Creek on August 21, 2011. The purpose of the inspection was to document site conditions following the peak 2011 spring/summer runoff. The 2011 water year was wet across the entire Sierra Nevada, with the Central Sierra region receiving approximately 180 percent of normal snow water equivalent (CDEC, 2011). Runoff in most drainages in the region was characterized by above average discharge rates sustained over a prolonged duration with respect to the mean annual condition. While I have not reviewed 2011 streamflow data for Oyster Creek, I presume that the Oyster Creek drainage experienced a period of sustained runoff approximating or slightly exceeding bankfull flow conditions. When I visited the site streamflow was largely due to seepage from Silver Lake.

The survey focused on previously identified erosion hotspots along the mainstem and North Tributary, although I did look for new erosion areas; none were identified. The mainstem of Oyster Creek continues to be on a trajectory toward recovery from historic incision and impacts from grazing. Adjustments in channel geometry, such as lateral erosion documented in previous field investigations (Blue Line Consulting, 2009), appears to be progressing at a slow rate. Erosion at the major cutbank locations continues to progress slowly, primarily due to groundwater sapping, rather than surface flow. The photo log included as an attachment to this memorandum provides comparison photos from 2007 and 2011. These photos support the observations described above.

The North Tributary also appears to be on a trajectory toward recovery. Visual observations suggest that there has been little or no progression of the knickpoint at the head of the main gully. A measurement was made of the length of the side gully that joins the North Tributary at River Station 3+50. The length of the side gully was roughly equivalent to that documented in the 2007 survey¹, indicating that the headward erosion rate is slow. Similarly, erosion in smaller gullies that drain into the main gully appeared to be relatively minor.

Conclusions & Recommendations

Field observations indicate that the 2011 spring/summer runoff did not cause significant erosion in the mainstem Oyster Creek or North Tributary. With 12 years² of quantitative and qualitative data on erosion rates and geomorphic form, it is evident that erosion is advancing at a slow rate and the site is on a trajectory toward recovery. There is no indication of livestock grazing in the meadow in the past 4 years. The cessation of grazing (a form of passive restoration) appears to be aiding in the recovery of riparian and meadow areas.

¹ The 2007 length of the side gully was derived from the 2007 topographic map based on aerial survey data and interpolation of contours. This methodology limits the precision repeated measurements of erosion at this location.

² Includes data from Doug Parkinson & Associates, 1999.

Oyster Creek is a “sensitive site” with high wetland functions and values, particularly with respect to native plant diversity in the meadow. At this junction, active intervention to stabilize streambanks and gullies with heavy mechanized equipment is not recommended because the potential benefits are outweighed by the risk of undesirable outcomes such as introducing non-native plant propagules and creating new erosion pathways, along with the temporary loss of functions and values associated with construction disturbance. At this time, it is recommended that biotechnical stabilization techniques (e.g., planting willow cuttings or wattles) implemented with hand labor be considered as a means of achieving project objectives.

References

Blue Line Consulting. 2009. Oyster Creek: Sensitive Site Monitoring. Prepared for El Dorado Irrigation District. August.

CDEC. 2011. Snow Water Equivalent for May 1, 2011. Accessed online at:
<http://cdec.water.ca.gov/cdecapp/snowapp/sweq.action>

ATTACHMENT C

**Oyster Creek Stabilization Plan
Construction Drawings**

OYSTER CREEK STABILIZATION PLAN

SHEET INDEX

- C1 COVER SHEET, ENGINEERING AND ACCESS
- C2 NORTH TYPICAL PLAN
- C3 BANK STABILIZATION PLAN
- C4 DETAILS

PROJECT DESCRIPTION

THESE PLANS PROVIDE DETAILS FOR THE STABILIZATION OF A PORTION OF OYSTER CREEK, LOCATED DOWNSHIP OF STATE ROUTE 88, IN THE COUNTY OF EL DORADO.

GENERAL NOTES

1. PLANS WERE PREPARED AT THE REQUEST OF:
 - A. EL DORADO IRRIGATION DISTRICT
 - B. 10000 IRRIGATION DISTRICT
 - C. EL DORADO IRRIGATION DISTRICT
 - D. EL DORADO IRRIGATION DISTRICT
 - E. EL DORADO IRRIGATION DISTRICT
 - F. EL DORADO IRRIGATION DISTRICT
 - G. EL DORADO IRRIGATION DISTRICT
 - H. EL DORADO IRRIGATION DISTRICT
 - I. EL DORADO IRRIGATION DISTRICT
 - J. EL DORADO IRRIGATION DISTRICT
 - K. EL DORADO IRRIGATION DISTRICT
 - L. EL DORADO IRRIGATION DISTRICT
 - M. EL DORADO IRRIGATION DISTRICT
 - N. EL DORADO IRRIGATION DISTRICT
 - O. EL DORADO IRRIGATION DISTRICT
 - P. EL DORADO IRRIGATION DISTRICT
 - Q. EL DORADO IRRIGATION DISTRICT
 - R. EL DORADO IRRIGATION DISTRICT
 - S. EL DORADO IRRIGATION DISTRICT
 - T. EL DORADO IRRIGATION DISTRICT
 - U. EL DORADO IRRIGATION DISTRICT
 - V. EL DORADO IRRIGATION DISTRICT
 - W. EL DORADO IRRIGATION DISTRICT
 - X. EL DORADO IRRIGATION DISTRICT
 - Y. EL DORADO IRRIGATION DISTRICT
 - Z. EL DORADO IRRIGATION DISTRICT
2. PROJECT COORDINATOR:
 - A. JAMES THOMAS
 - B. JAMES THOMAS
 - C. JAMES THOMAS
 - D. JAMES THOMAS
 - E. JAMES THOMAS
 - F. JAMES THOMAS
 - G. JAMES THOMAS
 - H. JAMES THOMAS
 - I. JAMES THOMAS
 - J. JAMES THOMAS
 - K. JAMES THOMAS
 - L. JAMES THOMAS
 - M. JAMES THOMAS
 - N. JAMES THOMAS
 - O. JAMES THOMAS
 - P. JAMES THOMAS
 - Q. JAMES THOMAS
 - R. JAMES THOMAS
 - S. JAMES THOMAS
 - T. JAMES THOMAS
 - U. JAMES THOMAS
 - V. JAMES THOMAS
 - W. JAMES THOMAS
 - X. JAMES THOMAS
 - Y. JAMES THOMAS
 - Z. JAMES THOMAS
3. TOPOGRAPHIC MAPPING PROVIDED BY:
 - A. LAW GEOGRAPHICAL, INC.
 - B. LAW GEOGRAPHICAL, INC.
 - C. LAW GEOGRAPHICAL, INC.
 - D. LAW GEOGRAPHICAL, INC.
 - E. LAW GEOGRAPHICAL, INC.
 - F. LAW GEOGRAPHICAL, INC.
 - G. LAW GEOGRAPHICAL, INC.
 - H. LAW GEOGRAPHICAL, INC.
 - I. LAW GEOGRAPHICAL, INC.
 - J. LAW GEOGRAPHICAL, INC.
 - K. LAW GEOGRAPHICAL, INC.
 - L. LAW GEOGRAPHICAL, INC.
 - M. LAW GEOGRAPHICAL, INC.
 - N. LAW GEOGRAPHICAL, INC.
 - O. LAW GEOGRAPHICAL, INC.
 - P. LAW GEOGRAPHICAL, INC.
 - Q. LAW GEOGRAPHICAL, INC.
 - R. LAW GEOGRAPHICAL, INC.
 - S. LAW GEOGRAPHICAL, INC.
 - T. LAW GEOGRAPHICAL, INC.
 - U. LAW GEOGRAPHICAL, INC.
 - V. LAW GEOGRAPHICAL, INC.
 - W. LAW GEOGRAPHICAL, INC.
 - X. LAW GEOGRAPHICAL, INC.
 - Y. LAW GEOGRAPHICAL, INC.
 - Z. LAW GEOGRAPHICAL, INC.
4. ELEVATION DATUM: NAVD 88
5. BASIS OF BENCHMARKS: STATE PLANE AND 83, ZONE 2
6. ELEVATIONS AND DISTANCES SHOWN ARE IN FEET AND DECIMALS THEREOF. CONTIGUOUS INTERVAL IS 2 FEET.
7. THIS IS NOT A BOUNDARY SURVEY. PROPERTY LINES, IF SHOWN, WERE COMPARED FROM RECORD INFORMATION AND FROM FIELD TIES TO EXISTING BOUNDARY MONUMENTATION. THE RECORD INFORMATION AND FROM FIELD TIES TO EXISTING BOUNDARY MONUMENTATION, THE BOUNDARY SURVEY LINES IS SUBJECT TO CHANGE, PENDING THE RESULTS OF A COMPLETE BOUNDARY SURVEY.

SECTION AND DETAIL CONVENTION

SECTION OR DETAIL IDENTIFICATION (NUMBER OR LETTER)

5

REFERENCE SHEET ON WHICH DETAIL OR SECTION IS TAKEN

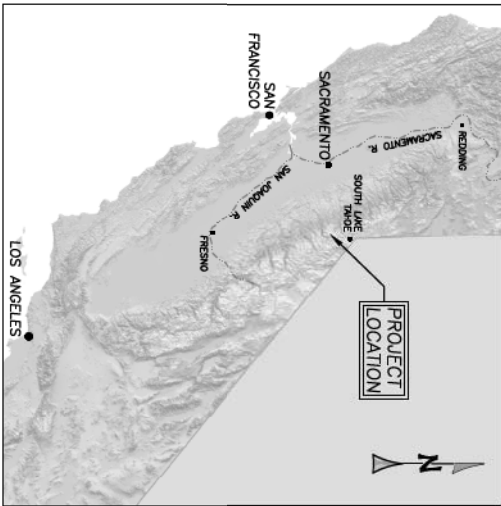
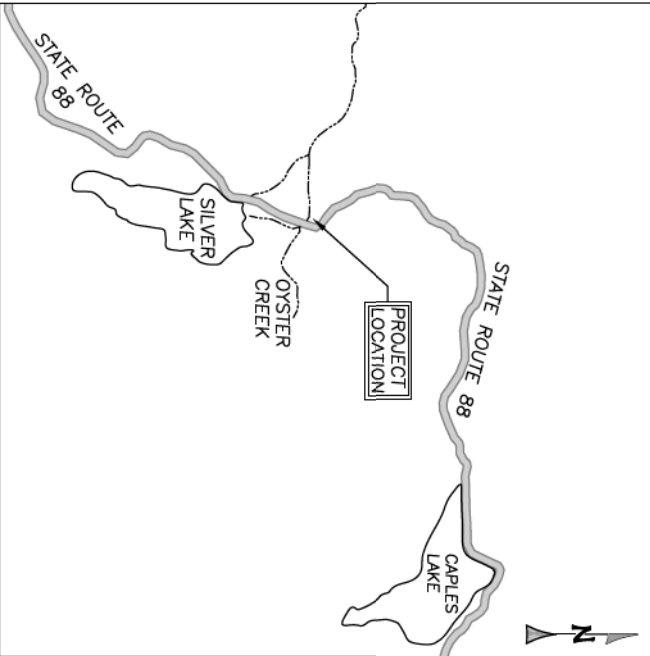

ABBREVIATIONS

AG	ADJUSTED
AL	ASPHALT
AM	ASPHALT CONCRETE
AN	ADJUSTED NUMBER
AR	ADJUSTED
AS	ADJUSTED
BS	ADJUSTED
CC	CONCRETE
CG	CONCRETE
CL	CONCRETE
CM	CONCRETE
CP	CONCRETE
CS	CONCRETE
CT	CONCRETE
CU	CONCRETE
CV	CONCRETE
CA	CONCRETE
CB	CONCRETE
CC	CONCRETE
CD	CONCRETE
CE	CONCRETE
CF	CONCRETE
CG	CONCRETE
CH	CONCRETE
CI	CONCRETE
CJ	CONCRETE
CK	CONCRETE
CL	CONCRETE
CM	CONCRETE
CN	CONCRETE
CO	CONCRETE
CP	CONCRETE
CQ	CONCRETE
CR	CONCRETE
CS	CONCRETE
CT	CONCRETE
CU	CONCRETE
CV	CONCRETE
CW	CONCRETE
CX	CONCRETE
CY	CONCRETE
CZ	CONCRETE
DA	CONCRETE
DB	CONCRETE
DC	CONCRETE
DD	CONCRETE
DE	CONCRETE
DF	CONCRETE
DG	CONCRETE
DH	CONCRETE
DI	CONCRETE
DJ	CONCRETE
DK	CONCRETE
DL	CONCRETE
DM	CONCRETE
DN	CONCRETE
DO	CONCRETE
DP	CONCRETE
DQ	CONCRETE
DR	CONCRETE
DS	CONCRETE
DT	CONCRETE
DU	CONCRETE
DV	CONCRETE
DW	CONCRETE
DX	CONCRETE
DY	CONCRETE
DZ	CONCRETE
EA	CONCRETE
EB	CONCRETE
EC	CONCRETE
ED	CONCRETE
EE	CONCRETE
EF	CONCRETE
EG	CONCRETE
EH	CONCRETE
EI	CONCRETE
EJ	CONCRETE
EK	CONCRETE
EL	CONCRETE
EM	CONCRETE
EN	CONCRETE
EO	CONCRETE
EP	CONCRETE
EQ	CONCRETE
ER	CONCRETE
ES	CONCRETE
ET	CONCRETE
EU	CONCRETE
EV	CONCRETE
EW	CONCRETE
EX	CONCRETE
EY	CONCRETE
EZ	CONCRETE
FA	CONCRETE
FB	CONCRETE
FC	CONCRETE
FD	CONCRETE
FE	CONCRETE
FF	CONCRETE
FG	CONCRETE
FH	CONCRETE
FI	CONCRETE
FJ	CONCRETE
FK	CONCRETE
FL	CONCRETE
FM	CONCRETE
FN	CONCRETE
FO	CONCRETE
FP	CONCRETE
FQ	CONCRETE
FR	CONCRETE
FS	CONCRETE
FT	CONCRETE
FU	CONCRETE
FV	CONCRETE
FW	CONCRETE
FX	CONCRETE
FY	CONCRETE
FZ	CONCRETE
GA	CONCRETE
GB	CONCRETE
GC	CONCRETE
GD	CONCRETE
GE	CONCRETE
GF	CONCRETE
GG	CONCRETE
GH	CONCRETE
GI	CONCRETE
GO	CONCRETE
GP	CONCRETE
GQ	CONCRETE
GR	CONCRETE
GS	CONCRETE
GT	CONCRETE
GU	CONCRETE
GV	CONCRETE
GW	CONCRETE
GX	CONCRETE
GY	CONCRETE
GZ	CONCRETE
HA	CONCRETE
HB	CONCRETE
HC	CONCRETE
HD	CONCRETE
HE	CONCRETE
HF	CONCRETE
HG	CONCRETE
HH	CONCRETE
HI	CONCRETE
HJ	CONCRETE
HK	CONCRETE
HL	CONCRETE
HM	CONCRETE
HN	CONCRETE
HO	CONCRETE
HP	CONCRETE
HQ	CONCRETE
HR	CONCRETE
HS	CONCRETE
HT	CONCRETE
HU	CONCRETE
HV	CONCRETE
HW	CONCRETE
HX	CONCRETE
HY	CONCRETE
HZ	CONCRETE
IA	CONCRETE
IB	CONCRETE
IC	CONCRETE
ID	CONCRETE
IE	CONCRETE
IF	CONCRETE
IG	CONCRETE
IH	CONCRETE
II	CONCRETE
IJ	CONCRETE
IK	CONCRETE
IL	CONCRETE
IM	CONCRETE
IN	CONCRETE
IO	CONCRETE
IP	CONCRETE
IQ	CONCRETE
IR	CONCRETE
IS	CONCRETE
IT	CONCRETE
IU	CONCRETE
IV	CONCRETE
IW	CONCRETE
IX	CONCRETE
IY	CONCRETE
IZ	CONCRETE

COVER	PREPARED AT THE REQUEST OF EL DORADO IRRIGATION DISTRICT		DATE: 2/22/12	<p>4038 SWIFT ST. SANTA CRUZ, CA 95060 PH: (831) 421-2291 / FAX: (888) 619-8847 WWW.WATERWAYS.COM</p>
OYSTER CREEK STABILIZATION PLAN	OYSTER CREEK STABILIZATION PLAN			
DESIGNED BY: M.M.W. CHECKED BY: M.M.W. DATE: 2-22-12	ORIGINAL DRAWING FOR ADJUST SCALING FOR OYSTER CREEK STABILIZATION PLAN			
C1	1 of 5			

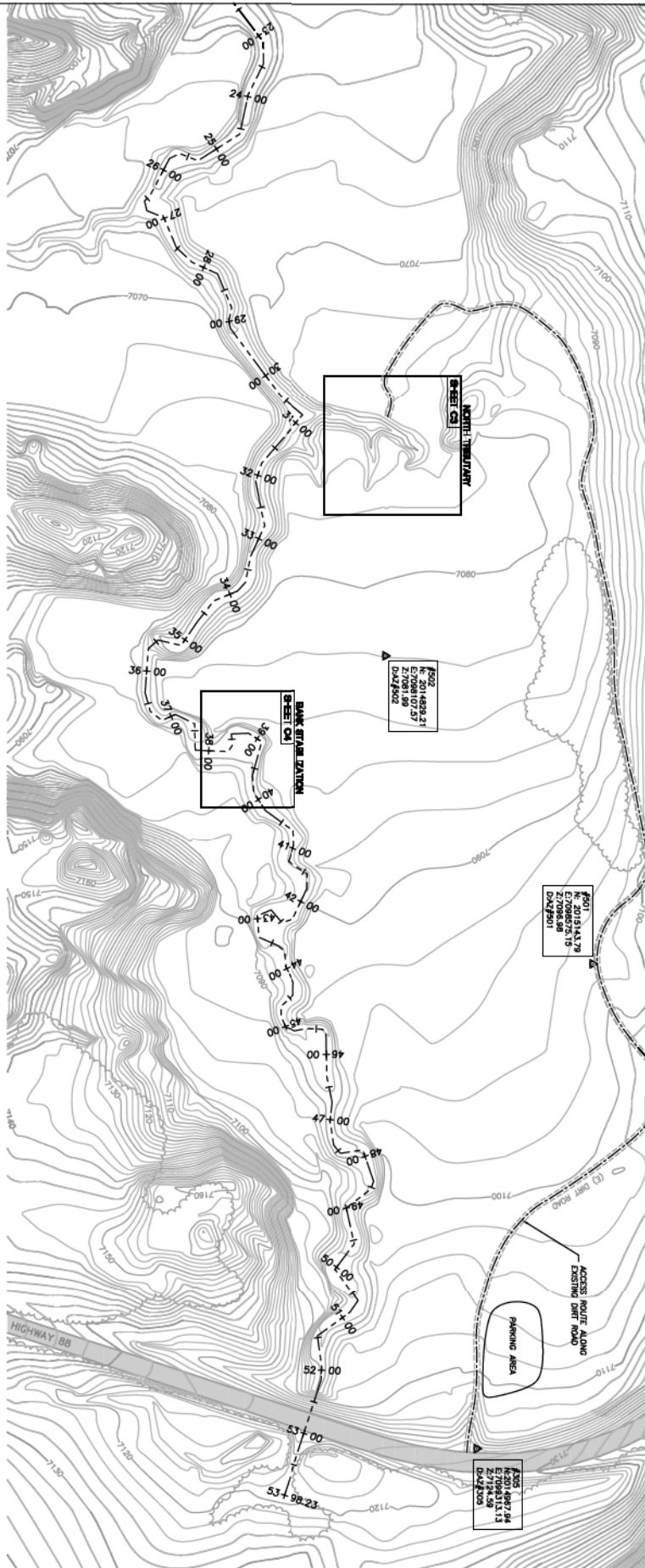

- ▲ CONTROL POINT
- DISPLINE
- EXISTING GROUND CONTOURS
- EXISTING DIRT ROAD
- STATION LINE

C2	5	DESIGNED BY: M.M.W.
		CHECKED BY: M.M.W.
		DATE: 2-22-12
		SCALE: AS SHOWN
		ADJUST SCALES FOR ORIGINAL DRAWING
		0

OYSTER CREEK STABILIZATION PLAN

SITE OVERVIEW AND ACCESS

PREPARED AT THE REQUEST OF
EL DORADO IRRIGATION DISTRICT

M.W.
MATT W. WELD

No. 62235
Exp. 6-30-13

2/22/12
DATE

WATERWAYS CONSULTING

4038 SWIFT ST.
SANTA CRUZ, CA 95060
PH: (831) 421-2291 / FAX: (831) 619-8847
WWW.WAYWAYS.COM



PHOTO 1 VIEW LOOKING UPSTREAM WITHIN NORTH TRIBUTARY

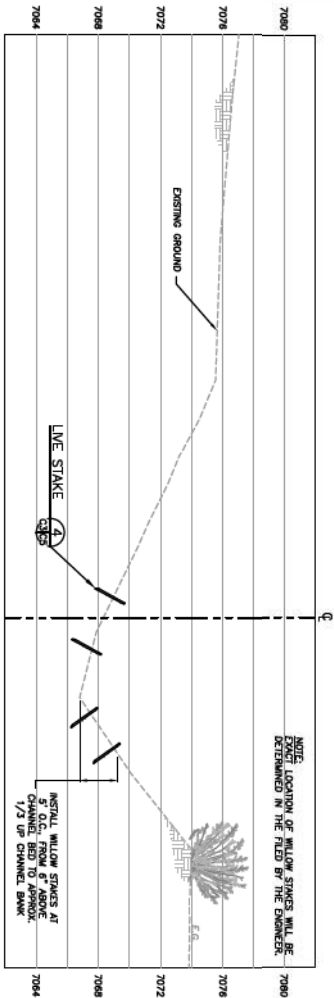

NORTH TRIBUTARY TYPICAL SECTION
SCALE: 1"=1'

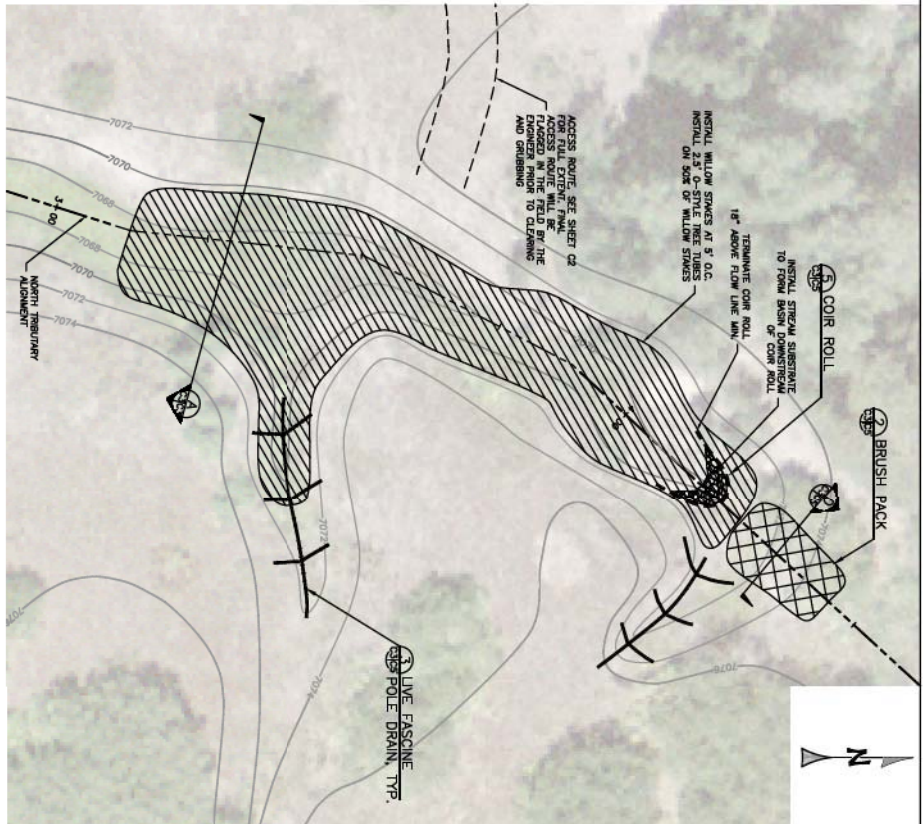

NORTH TRIBUTARY PLAN
SCALE: 1"=10'

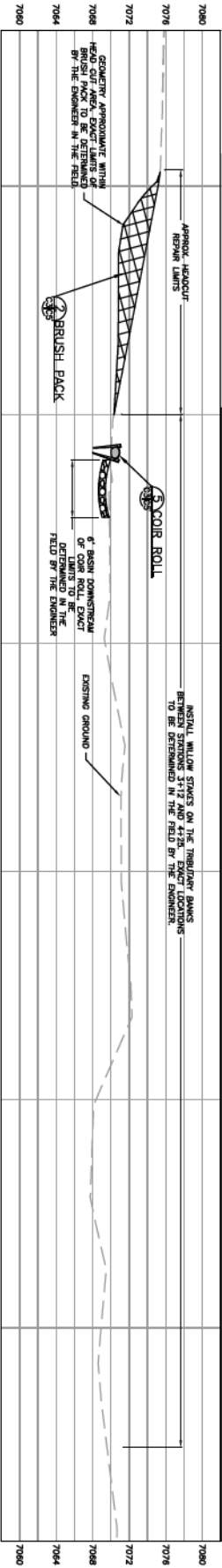

NORTH TRIBUTARY PROFILE
SCALE: 1"=10'

<p>DESIGNED BY: M.M.W. ENGINEER: M.M.W. CHECKED BY: M.M.W. DATE: 2-22-12 SCALE: AS SHOWN ADJUST SCALES FOR ORIGINAL DRAWING</p>	<p>REVISIONS: 0 1 2 3</p>	<p>OYSTER CREEK STABILIZATION PLAN</p>	<p>NORTH TRIBUTARY SITE PLAN</p>	<p>PREPARED AT THE REQUEST OF EL DORADO IRRIGATION DISTRICT</p>		<p>4/22/12 DATE</p>	<p>WATERWAYS CONSULTING 4038 SWIFT ST. SANTA CRUZ, CA 95060 PH: (831) 421-2281 / FAX: (831) 619-8847 WWW.WATWAYS.COM</p>
						<p>C3</p>	

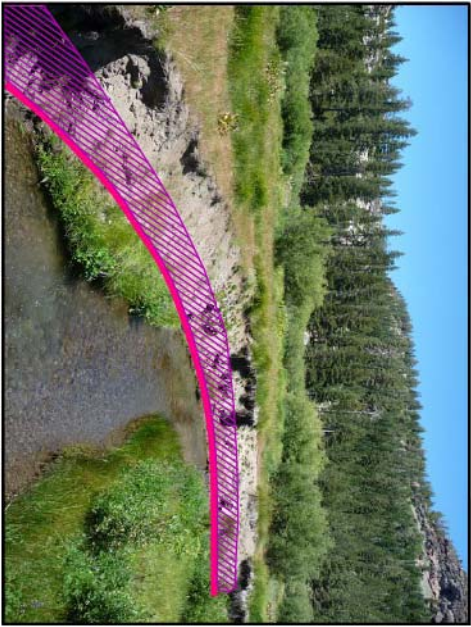
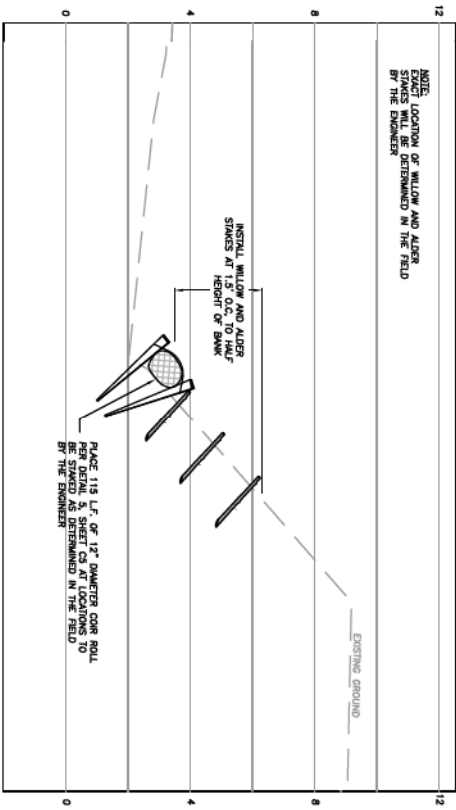

PHOTO 2: EROSION STEPS/BANK (STA. 39140 - 39140)



NOTE:
EXACT LOCATION OF WILLOW AND ALDER STAKES TO BE DETERMINED IN THE FIELD BY THE ENGINEER.

INSTALL WILLOW AND ALDER STAKES AT HEIGHT OF BANK

PLACE 115 L.F. OF 12" WEAVER COIR ROLL PER DETAIL & SHEET C4 AT LOCATIONS TO BE DETERMINED IN THE FIELD BY THE ENGINEER

EXISTING GROUND

TYPICAL SECTION (STA. 39159 - 40100)  SCALE 1/4" = 1'-0"

NOTE: ORIGINAL TOPOGRAPHY LINES OBTAINED FROM AERIAL PHOTOGRAPHY. ELEVATION DATA SHOWN BELOW THE WATER SURFACE. THE EXISTING GROUND DATA SHOWN IN THIS SECTION IS SUPERIMPOSED WITH DATA FROM A SURVEY CONDUCTED IN SEPTEMBER, 2007. DIMENSIONS SHOWN ARE BASED ON THE DATUM COMPLETED BY SHAWSON HYDROLOGY.



BANK STABILIZATION PLAN (STA. 39159 - 40100)  SCALE 1/4" = 1'-0"



		PREPARED AT THE REQUEST OF EL DORADO IRRIGATION DISTRICT	BANK STABILIZATION PLAN (STA. 39159 - 40100)	OYSTER CREEK STABILIZATION PLAN	DESIGNED BY: M.W.W. CHECKED BY: M.W.W. DATE: 2-22-12 DRAWN BY: M.W.W. ORIGINAL DRAWING: 0 (REVISION 1)	SCALE: 1/4" = 1'-0"	SHEET: 4 OF: 7
					WATERWAYS CONSULTING 4038 SWIFT ST. SANTA CRUZ, CA 95060 PH: (831) 421-2291 / FAX: (831) 619-8847 WWW.WATWAYS.COM		

Table 1: Gradation requirements for Stream Substrate, inches or 2.54 cm size

100% passing	no. 40	no. 20	no. 10	no. 5
12	4	13/4	0.50	No. 10

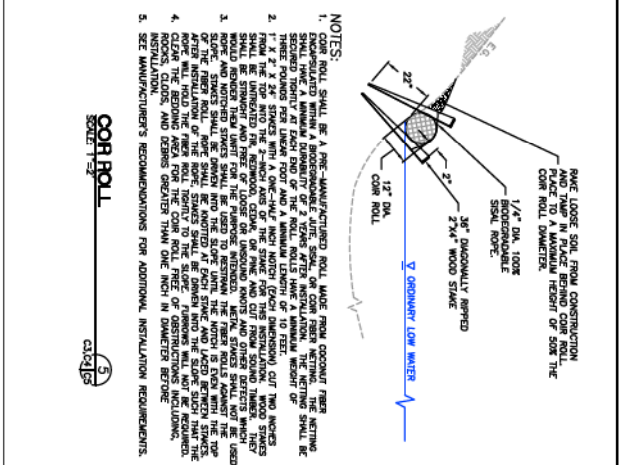
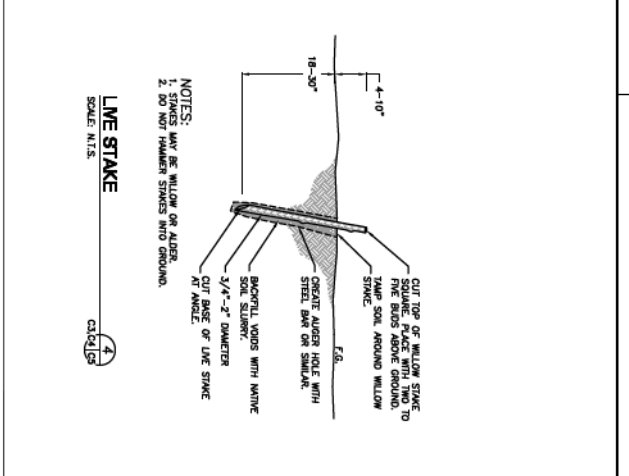
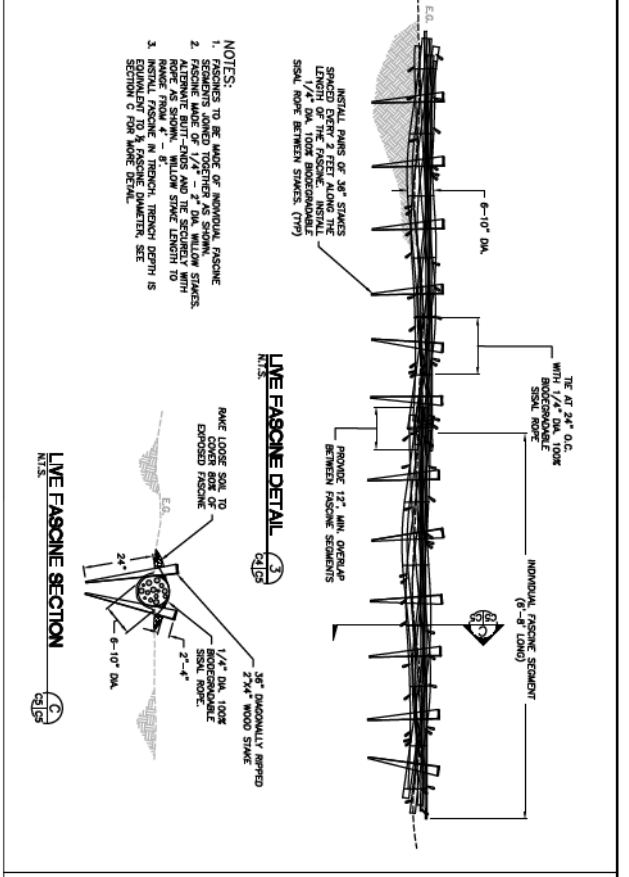
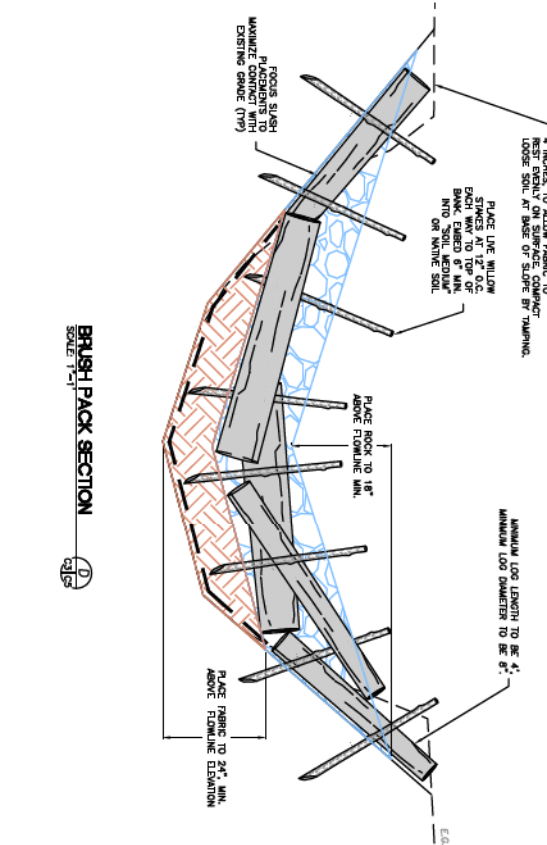
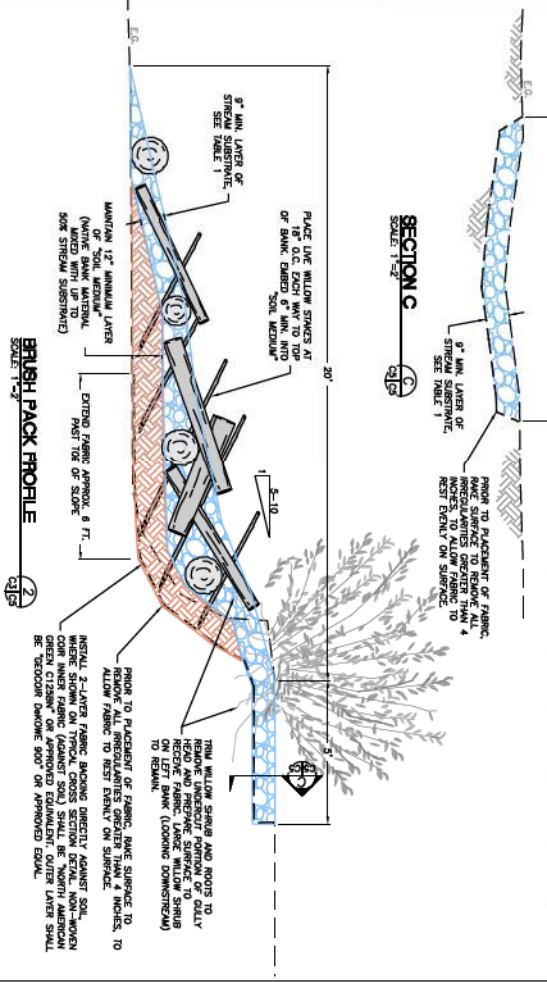

PREPARED AT THE REQUEST OF EL DORADO FRIGATION DISTRICT

DATE: 4/22/12

MATT W. WELD

WATERWAYS CONSULTING

4038 SWIFT ST. SANTA CRUZ, CA 95060 PH: (831) 421-8282 / FAX: (831) 421-8283 WWW.WATERWAYS.COM

OYSTER CREEK STABILIZATION PLAN

DESIGNED BY: A.M.W. DATE: 11/20/11

CHECKED BY: A.M.W. DATE: 2-22-12

DESIGNED BY: A.M.W. DATE: 11/20/11

SCALE: N.T.S.