

PROPOSED BEST MANAGEMENT PRACTICES FOR SEDIMENT, ROCK AND BRUSH REMOVAL FROM THE EL DORADO CANAL FERC PROJECT 184

Revision 3: October 3, 2002



This report has been prepared under the responsible charge of:
Dr. Scott E. Shewbridge, Ph.D., RCE
California License Number 47847

**El Dorado Irrigation District
2890 Mosquito Road
Placerville, California 95667**

TABLE OF CONTENTS

<u>Section No.</u>	<u>Topic</u>
1.0	Introduction
2.0	Description of Materials to Be Removed
3.0	Erosion, Sediment and Spill Control BMPs
4.0	Work Plan
Table 1	Results of Sediment STLC Testing
Figure 1	Grading Detail for Placement of Canal Sediment on Levee Crest
Figure 2	Grading Detail for Placement of Canal Sediment on Bench Outboard of Levee
APPENDIX A	Certified Analytical Reports
APPENDIX B	Site-Specific Sediment Control BMPs

1.0 INTRODUCTION

The El Dorado Canal (the canal) is located in the vicinity of the South Fork of the American River in El Dorado County, California. The canal is approximately 22 miles long from its intake near Kyburz to the Forebay Reservoir and El Dorado Powerhouse near Pollock Pines (Federal Energy Regulatory Commission [FERC] Project 184). The canal is a conveyance system consisting of a diversion and intake structure, fully-lined gunite canal sections (full-shell), canal sections lined only on the outside wall and half of the bottom (half-shell), L-wall concrete sections, wooden and pre-cast concrete flumes, three covered sections, two siphons, and three tunnels.

During the course of canal operation, sedimentation occurs at various locations in the canal, including (but not limited to) “dead spots” near bends, locations where the canal widens abruptly, at the foot of access ramps that enter the canal, locations where large debris (e.g., rock fall) has accumulated, engineered “sand traps”, and locations where plants or saplings have begun to grow in the canal. The sedimentation takes the form of sand bars or silt bars which, depending on the location, may have saplings or plants growing from them. Historically, the primary source of these materials was sediment suspended in waters diverted from the South Fork of the American River, and the tributary streams intercepted by the canal. With the new, constructed diversion dam, suspended sediment loads should be greatly reduced. The canal also contains rock derived from rockfall or landslides that enter on the canal.

For over a century, PG&E and then the El Dorado Irrigation District (EID) have removed these materials from the canal as part of routine maintenance. The removed material enhances flow and water quality in the canal, and reduces siltation of the Forebay. Traditionally, some of these materials are released back into tributary streams from the sediment traps located at spillways. These releases help maintain the natural sediment bed loads that are otherwise reduced by operation of the canal, and addresses past California Department of Fish and Game concerns that maintenance practices encourage return of the sediments to the river via the tributary streams.

This document discusses the planned activities for sediment removal from the canal during 2002. This program will focus on an approximately 10-mile segment of canal from the downstream portal of the Esmeralda Tunnel to the Forebay. This document includes a discussion of the chemical leaching potential of the sediment, anticipated locations and methods of sediment removal, sediment management practices, and best management practices (BMPs) for preventing sediment runoff. The BMPs presented in this document are site-specific, and were developed by qualified personnel who are familiar with EID’s maintenance activities, and methods of control and elimination of potential non-point source pollution.

The diversion dam that was recently re-constructed on the South Fork of the American River is designed to reduce river bed load entrainment into the canal and should reduce future sediment maintenance requirements for the canal. Sediment and debris removal from the intake for the diversion dam following flood events is being addressed through a separate EID maintenance program.

2.0 DESCRIPTION OF MATERIALS TO BE REMOVED

The following types of materials will be removed as part of this maintenance program:

- Silt bars
- Sand bars
- Plants and saplings that have established themselves in sediment bars
- Rock from rock fall and land slides.

2.1 Locations and Estimated Quantities

Sedimentation has occurred at various locations along the canal. Typically, these locations include (but are not limited to) “dead spots” near bends, locations where the canal widens abruptly, at the foot of access ramps that enter the canal, locations where large debris (e.g., rock fall) has accumulated, engineered “sand traps”, and locations where plants or saplings have begun to grow in the canal. The 2002 removal program will address an approximately 10-mile segment of canal from the downstream portal of the Esmeralda Tunnel to the Forebay.

The estimated quantity of sediments to be removed is 200 cy over the 10-mile-length of the 2002 program.

2.2 Chemical Behavior of Sediments

From a water-quality perspective, the materials of greatest concern are the silty sediments. These are a concern both because of their direct contribution to suspended solids loads and turbidity, as well as their potential to act as sources of adsorbed metals. Fine-grained sediments such as silt or clay may adsorb dissolved metals, and may release such metals if the sediments are placed in aqueous environments of lower pH, higher ionic strength, or that differ in other ways from the environment in which the sediments adsorbed metals. Sediments found in the canal are essentially in contact with the same aqueous environments that they were in prior to entering the canal: the waters of the South Fork of the American River, and streams tributary to that river. Because the sediments have equilibrated with the American River and canal environments, they are not expected to act as a source of metals release, either to the canal, or to surface waters if they are placed into levee material.

At the request of the Regional Water Quality Control Board (RWQCB), EID had canal sediments analyzed for their potential to leach metals (once the sediments are placed onto the levee crest) to surface waters via contact with rainfall runoff or snow melt. EID collected a total of 4 sediment sample on August 28, 2002, one from each of the following locations:

- Sample SED-1 (a brown, poorly-graded gravelly, silty sand with high organic content) collected 20 feet upstream of the Old Camp 5 Bridge on Hazel Creek Road.

- Sample SED-2 (a gray, poorly-graded gravelly, silty medium sand) collected 40 feet downstream of first footbridge upstream of the Old Camp 5 Bridge. This is approximately 0.5 miles upstream of sample SED-1.
- Sample SED-3 (a brown mixture of silt and fine sand, with pine needles) midway between samples SED-1 and SED-2. This is approximately 0.25 miles upstream of sample SED-1.
- Sample SED-4 (a gray sandy silt) collected at the first footbridge downstream of the Old Camp 5 Bridge. This is approximately 0.25 miles downstream of sample SED-1.

Together these samples represent a 0.75-mile-long portion of the 10-mile-long project scope.

After consultation with the RWQCB, each of these samples was analyzed for its Soluble Threshold Limit Concentration (STLC) via a California Waste Extraction Test (WET) using a deionized water, and subsequent analysis for dissolved metals by AA or ICP.

The results of this analysis is presented in Table 1. Certified Analytical Results (CARs) for these sample, as well as the Chain-of-Custody documentation, are presented in Appendix A. The results indicate that no detectable concentrations of metals are leached from any of the sediment samples following a California WET with deionized water. These results demonstrate that the sediments do not act as a source of desorbable metal ions, and that the sediments will not release metals to surface waters if the sediments are used as levee materials for the canal system.

Table 1
Dissolved Metals Concentrations Resulting from El Dorado Canal Sediments
That Were Extracted by the California Waste Extraction Test (WET) Using Deionized Water

Elements (Symbol)	STLC mg/L	Sample #: SED-1	Sample #: SED-2	Sample #: SED-3	Sample #: SED-4	Average
Antimony (Sb)	15	ND(0.50)	ND(0.50)	ND(0.50)	ND(0.50)	ND(0.50)
Arsenic (As)	5.0	ND(0.050)	ND(0.050)	ND(0.050)	ND(0.050)	ND(0.050)
Barium (Ba)	100	ND(0.50)	ND(0.50)	ND(0.50)	ND(0.50)	ND(0.50)
Beryllium (Be)	0.75	ND(0.10)	ND(0.10)	ND(0.10)	ND(0.10)	ND(0.10)
Cadmium (Cd)	1.0	ND(0.10)	ND(0.10)	ND(0.10)	ND(0.10)	ND(0.10)
Chromium (Cr), Total	5	ND(0.50)	ND(0.50)	ND(0.50)	ND(0.50)	ND(0.50)
Cobalt (Co)	80	ND(0.50)	ND(0.50)	ND(0.50)	ND(0.50)	ND(0.50)
Copper (Cu)	25	ND(0.50)	ND(0.50)	ND(0.50)	ND(0.50)	ND(0.50)
Lead (Pb)	5.0	ND(0.50)	ND(0.50)	ND(0.50)	ND(0.50)	ND(0.50)
Mercury (Hg)	0.2	ND(0.050)	ND(0.050)	ND(0.050)	ND(0.050)	ND(0.050)
Molybdenum (Mo)	350	ND(0.50)	ND(0.50)	ND(0.50)	ND(0.50)	ND(0.50)
Nickel (Ni)	20	ND(0.50)	ND(0.50)	ND(0.50)	ND(0.50)	ND(0.50)
Selenium (Se)	1.0	ND(0.050)	ND(0.050)	ND(0.050)	ND(0.050)	ND(0.050)
Silver (Ag)	5.0	ND(0.50)	ND(0.50)	ND(0.50)	ND(0.50)	ND(0.50)
Thallium (Tl)	7	ND(0.050)	ND(0.050)	ND(0.050)	ND(0.050)	ND(0.050)
Vanadium (V)	24	ND(0.50)	ND(0.50)	ND(0.50)	ND(0.50)	ND(0.50)
Zinc (Zn)	250	ND(0.50)	ND(0.50)	ND(0.50)	ND(0.50)	ND(0.50)
Hexavalent Chromium (Cr+6)	None	ND(10)	ND(10)	ND(10)	ND(10)	ND(10)

Notes:

All samples extracted by California Waste Extraction Test (WET), and then analyzed by STLC: Soluble Threshold Limit Concentration, per California Code of Regulations (CCR), Title 22.

The STLC criteria is not applicable to river sediments, which are not wastes.

ND(#): Analyte not detected at the indicated method detection limit, in mg/L.

mg/L: milligrams of analyte per litre of water. Equivalent to parts per million (ppm).

3.0 EROSION, SEDIMENT AND SPILL CONTROL BMPs

Applying proper erosion and sediment control measures is the most effective approach to reducing potential pollutants emitted from the maintenance activities. The following erosion and sediment control BMPs have been selected for this project:

- Watering for Dust Control
- Erosion Control Blanket
- Fiber Rolls
- Reseeding

Detailed design, installation, and maintenance procedures for these BMPs are included in Appendix B. Appendix A includes selections from the State of California Department of Transportation Construction Site Best Management Practices (BMP) Manual.

3.1 Practices to Minimize Contact with Storm Water

3.1.1 Construction Vehicles and Equipment

All on-site routine maintenance, fueling and washing will be carried out in staging areas located away from waterways and inlets. The areas will be contained within earthen berms, lined with impermeable plastic sheeting. All routine maintenance and fueling of equipment will take place within staging areas.

Maintenance – Equipment will be stored and maintained on-site during construction in the staging areas. These will be designated dry areas, and washing will only be done during the project if absolutely necessary. Preventative measures, such as inspecting hydraulic hoses and gaskets will be done routinely. Any fuel tanks must be contained in a lined basin.

Fueling – All refueling will take place at the staging areas. Refueling will be done by fuel truck. The staging areas will have absorbent materials on-hand to collect a fuel spill.

Washing – Equipment washing, if needed, will be done in the staging areas to minimize spreading pollutants (e.g., oils). Attempts will be made to wipe down equipment, and to minimize use of water to keep the staging areas dry.

Materials – Fuel, lubricants, hydraulic oil, cleaning agents and other chemical agents needed for onsite maintenance will be stored in secure, covered, liquid-tight containers (e.g., steel job boxes, or plastic-lined fruit bins with covers) located near the staging area, where they will be protected from the elements. The boxes will act as secondary containment for fuel or other mobile liquids. Non-hazardous products providing equivalent performance will be used whenever possible.

3.2 Waste Management and Disposal

Waste collection areas will be established at access bridges or ramps, and the refuse will be removed daily when the crews leave the job site.

Because of the remote nature of the site, limited area to work on the levee crest, and short duration of the project, no concrete wash-out area will be constructed or used.

No portable toilets are provided. Crew members will bury human waste at least 100 feet from the canal, tributaries or drainage courses.

3.3 Spill Contingencies

Allowable non-stormwater discharges to receiving waters from the construction site include:

- Discharges from fire fighting;
- Potable water sources;
- Naturally occurring water from springs and riparian areas;
- Irrigation water discharged during temporary seeding;
- Wash water for dust control, and necessary equipment washing;
- Emergency spillway operation in response to alarms; and
- Approved discharges from spillways for maintenance purposes.

3.3.1 Minor Spills

Minor or insignificant spills shall be cleaned up immediately by the EID crew or responsible subcontractor. Because of the remote location and difficulty of communication, the on-site personnel will respond first, and contact the following local agencies after the remedial actions are performed, and/or if additional support is needed:

- El Dorado Sheriff's Department (530) 621-5663
- El Dorado Fire Station (530) 622-3858
- CDF, Fire Protection (530) 644-2345
- Regional Water Quality Control Board (916) 255-3364
- California Department of Fish and Game (916) 358-2900

Minor spills should be addressed as follows:

- Contain the spill by fashioning an earthen dike, and using impermeable plastic sheeting.
- Use absorbents to soak up the material. Dispose of used absorbent and contaminated soil.
- Cover the impacted area to avoid runoff.
- Record the work done.

- Notify the regulatory agencies.

3.3.2 Major Spills

If there is a spill that the crew thinks may be significant, contact the Engineering Manager of the Hydroelectric and Watershed Management Division. Engineering support will be dispatched to determine if a reportable quantity of materials has been released, and to provide other regulatory and technical support.

If there is a major spill, the crew should attempt to control the spill until the appropriate, qualified emergency response staff arrive at the site. In addition to the agencies listed in above in Section 5.14.1, the following agencies should be contacted for major spills:

- The National Response Center (800) 424-8802
- Governor's Office of Emergency Services Warning Center:
(800) 852-7550.

Written reports should be filed with these agencies following cleanup.

4.0 WORK PLAN

The following activities will be performed as part of the maintenance

4.1 Project Site Access

Deer and Foot Bridges – Where bridges are used for access, and soil at the bridge entrance or exit are not vegetated or covered by duff, then fiber rolls will be applied at these locations.

Earthen Ramps – Most of the access ramps in the project area are gunite ramps, and do not require erosion control. Where earthen ramps are used, erosion mats will be installed at the base of the earthen ramp where it enters the canal. The erosion blanket should extend about 6 feet above current water levels to allow for higher water levels when the canal operates at full flow. Additional fiber rolls may be needed above the erosion mats, depending on the length and groundcover on the ramps.

4.2 Equipment Maintenance and Supply Storage

Before additional equipment is brought to the site, a storage, maintenance and refueling area will be established for the canal's levee sections where work is being conducted. The storage area will be located at least 100 feet from the canal, or springs or tributaries. All equipment will be fueled, maintained and stored in the storage areas. Impermeable plastic sheeting will be used to line the area where refueling or maintenance occurs.

The storage area will have secure, lined, covered storage for any maintenance chemicals or chemical-containing equipment that are stored on site. In the storage area, EID will also store absorbent materials for spill cleanup, bags for refuse, and a spare coil of fiber rolls and wooden stakes for quick deployment in case of an unseasonable storm.

4.3 Removal of Materials from the Canal

Earthen materials will be removed from the canal using bobcats, and other small-footprint, track-mounted excavators. Materials will be placed on the levee crest in temporary stockpiles. Materials will NOT be sidecast over the outboard side of the levee. Saplings and brush will be removed by chain saws, "weed eaters" or hand tools. Saplings of 4-inch diameter or less will be removed from the outboard slope of the canal.

4.4 Materials Segregation

Burnable Organic Matter - Organic matter, including saplings, cattails, and other plants will be separated from sediments and stockpiled in burn piles for burning during the rainy season. Burn piles may be located off of the levee crest with the review of Dave Buel, and approval of the property owner. EID may elect to “chip” these materials with a wood chipper, and place the resulting chips on the levee crest or outboard slope of the levee to act as mulch, to foster the growth of plants, and development of “duff” in these areas.

Non-Burnable Organic Matter - Organic matter that has poor burn properties (e.g, grasses that retain significant soil in their roots) may be placed in decomposition piles. These piles must be located entirely off of the levee, because of the potential for such piles to attract burrowing animals.

Rock – Rock of less than 4” diameter may be placed with sediments for compaction. Rock of greater than or equal to 4” diameter may be placed with sediments provided it is located more than one rock diameter in all directions from other rock. If rock cannot be dispersed as described above, it will reduce the effectiveness of compaction, and may result in honeycombing, and subsequent erosion and/or pipe flow failures.

If the quantity or density of rock prevents placement as described above, then the rock will be stockpiled at locations on the levee crest for future use as armor for erosion control in and around the canal.

4.5 BMP Inspection Prior to Demobilization

Project workflow is as follows. The canal will be worked in segments, typically a half mile to 2 miles in length, that are defined by (1) features such as tunnels and flumes that cannot be crossed by construction equipment, and (2) access roads and suitable staging/storage areas for equipment. The crew will first complete removal of sediments from the canal portion. The removed sediments will dry as work progresses. Typically this work will last a week or so, allowing sediments to dry somewhat, but retain some moisture to aid in compaction. At the completion of sediment removal, the crew will return to the oldest (generally the driest) removed sediment, and grade/place and compact this material. The placement of sediments removed from the canal will be completed before equipment is mobilized to the next canal segment.

The BMP inspection will consider the location of downslope tributaries.

Prior to mobilizing equipment, there will also be an inspection to see if additional BMPs are required before completing the work. The inspection will be performed by an individual designated by the Engineering Manager of the Hydroelectric and Watershed Management Division. Notify Whit Smith at (530) 642-4026 to schedule

an inspection prior to demobilizing. Please try to provide at least 24-hour notice to schedule inspections.

4.6 Temporary Sediment Stockpiles

As described in Section 4.5 above, sediment will be stockpiled temporarily during sediment removal across the entire length of a canal segment. Typically this will take a few days to a week, and will allow the sediment to dry. Under this situation, no BMPs will be required to control sediment migration.

If stockpiled sediment is being left for a longer period, and equipment is being demobilized from the canal segment; or if rainfall is expected, then the base of the stockpile will be ringed with fiber rolls. Stakes may be driven shallowly, as the stockpiles should be placed soon thereafter, and the rolls will need to be removed at that time.

4.7 Grading Sediment On Levee Crest: Locations Where the Levee Crest Width Exceeds 8 Feet

Areas of the levee which are wide enough to allow equipment access (generally 8-foot or wider) and are otherwise suitable, may have sediments managed through spreading and compaction on the levee crest. Areas selected for soil spreading and grading will be grubbed of vegetation prior to spreading sediment. Soil will be placed in lifts with a maximum thickness of 3 inches, and will be compacted. The levee should be graded with the profile shown in Figure 1. The levee crest will be graded to a 3 percent slope (100H:3V) sloping away the canal. The inboard slope of the levee should be graded at a 2:1 (H:V) slope. Except for grubbing where sediments will be placed at the "hinge" between the crest and outboard slope, site grading will not disturb the groundcover, or alter the angle of the natural, outboard levee slope. Because of the difficulty of controlling moisture content of these soils during grading, no attempt will be made at achieving a compaction specification. The crew will compact according to their judgment as materials, access and equipment allow.

The crew will take not place soils that have excessive organic content (more than 40% by volume). Such materials should be placed in decomposition piles located off of the levee, or burn piles on or near the levee.

During grading, if construction activities and wind conditions are causing visible dust migration, then dust control will be instituted. Water will be taken from the canal via portable pump, and sprayed at a rate of approximately 0.125 gal/ square yard every 20 to 30 minutes. Care will be taken not to apply excessive water, as this could result in sediment runoff to the canal. Refer to Specification WE-1 in Appendix B.

ANNUAL
DITCH
MAINTENANCE

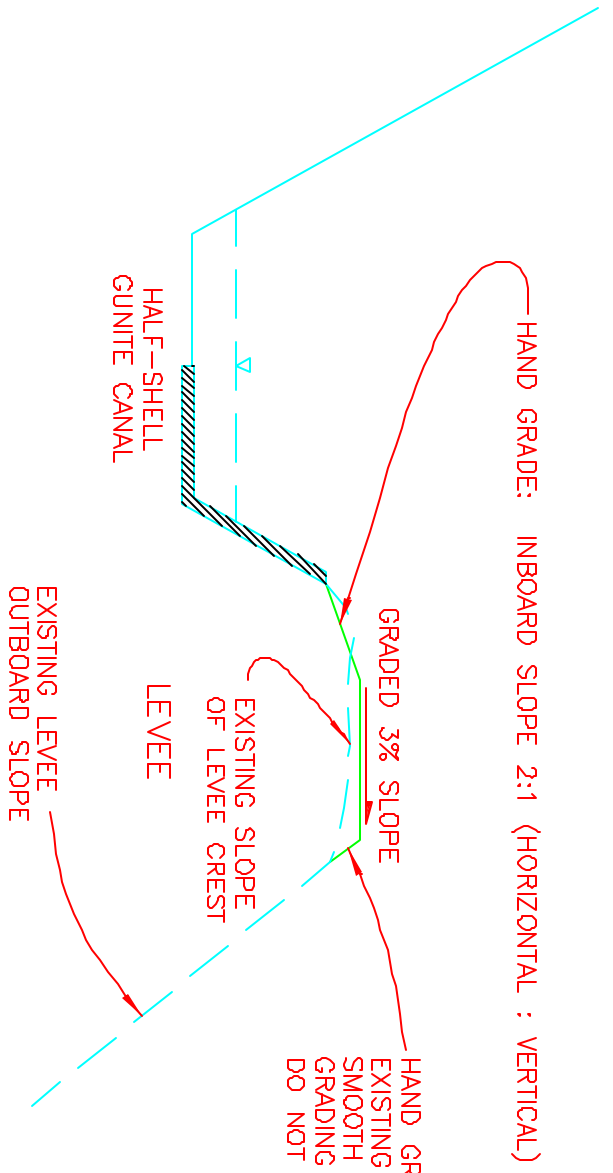

HAND GRADE TO MATCH
EXISTING OUTBOARD SLOPE.
SMOOTH TRANSITION BETWEEN
GRADING AND OUTBOARD SLOPE.
DO NOT DISTURB OUTBOARD SLOPE.

- NOTES:
1. LEVEE CREST TO BE GRUBBED PRIOR TO SEDIMENT PLACEMENT
 2. SEDIMENT TO BE PLACED IN LIFTS OF THICKNESS OF 3 INCHES OR LESS.
 3. COMPACT LIFTS ON LEVEE CREST BY ROLLING EQUIPMENT WITHOUT MOISTURE CONTROL.
 4. HAND GRADE AND HAND COMPACT SOIL PLACED ON INBOARD AND OUTBOARD SLOPES OF LEVEE.

EL DORADO IRRIGATION DISTRICT

GRADING DETAIL

PLACEMENT OF CANAL SEDIMENT
ON LEVEE CREST OF GREATER THAN 8' WIDTH

DRAWN BY WHIT SMITH	SCALE NONE	REVISION	DATE	BY
APPROVED SCOTT SHEMBRIDGE	DATE 9/5/02			ED STANDARD DRAWING NO. FIGURE 1

ANNUAL
DITCH
MAINTENANCE

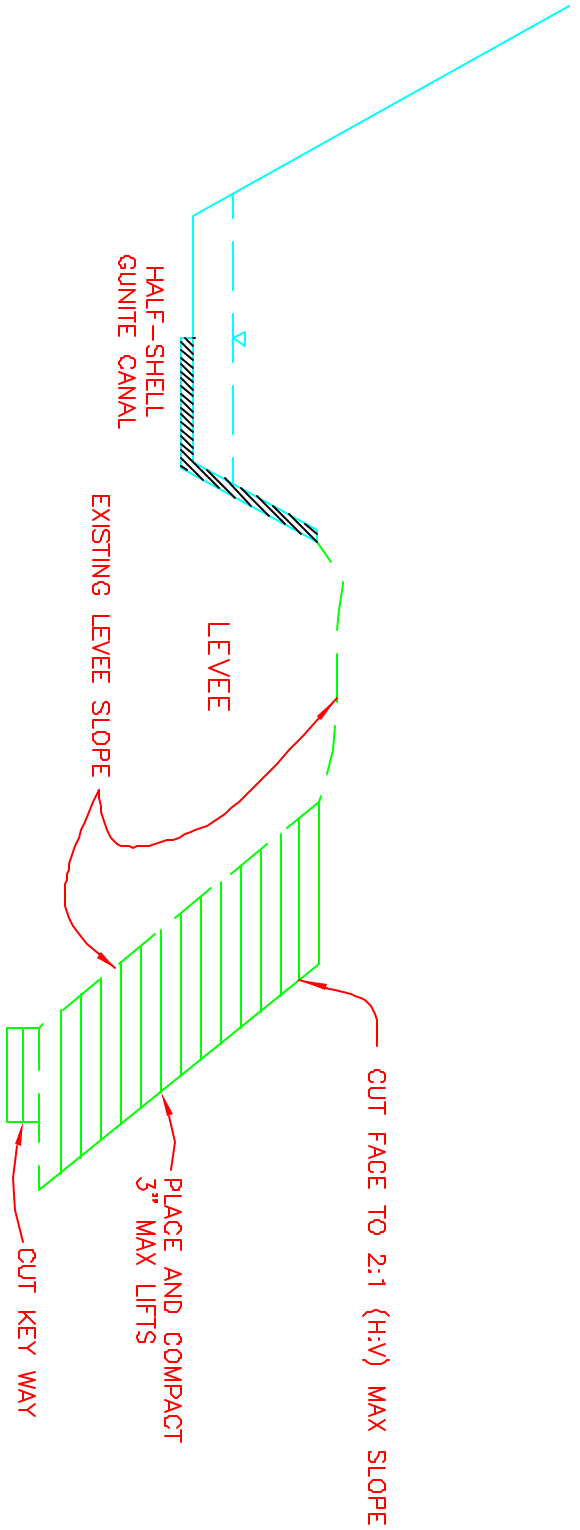

- NOTES:
1. THIS APPROACH SHALL ONLY BE USED ON LEVEE SECTIONS LESS THAN 8 FEET WIDE, WITH AN OUTBOARD SLOPE OF 2:1 (H:V) OR LESS, [OR 1.5:1 (H:V) OR LESS WITH BMP INSTALLATION].
 2. GRUB THE OUTBOARD LEVEE FACE AND TOE OF THE LEVEE.
 3. CUT A KEYWAY AT THE TOE OF THE LEVEE.
 4. PLACE THE BEST SOIL MATERIAL AVAILABLE IN THE KEYWAY, 3 INCH MAX LIFTS, COMPACT EACH LIFT.
 5. PLACE SEDIMENT IN 3 INCH MAX LIFTS ON KEYWAY AND BUILD TO LEVEE CREST. COMPACT EACH LIFT.
 6. CUT FACE TO 2:1 (H:V) MAX SLOPE AND PLACE SPOILS IN LIFTS TO SIDE, GRADE INTO CREST, OR PLACE IN CANAL FOR SCOUR. SLOPE MAY BE CUT TO 1.5:1 (H:V) MAX SLOPE IF BMPs ARE USED.

EL DORADO IRRIGATION DISTRICT

LIFT PLACEMENT DETAIL

BY BUILDING SEDIMENT ON LIFTS ON OUTBOARD FACE OF LEVEE
EXPANDING LEVEE WIDTH

DRAWN BY WHIT SMITH	SCALE NONE	REVISION	DATE	BY
APPROVED SCOTT SHEMBRIDGE	DATE 9/5/02			
				EID STANDARD DRAWING NO. FIGURE 2

If the grading occurs within 100 feet of a spring or tributary, then fiber rolls will be placed so as to filter runoff from the graded area. Refer to Specification SC-5 in Appendix B.

4.8 Benched Sediment Placement: Locations Where the Levee Crest Width Is Less Than 8 Feet

In areas where the levee crest is narrower than 8-feet, and it is beneficial to operations to expand the width of the crest for equipment access, then the crest may be widened by adding layers to a bench on the outboard face of the levee. **This may only be done on outboard levee slopes of 2:1 (H:V) or less (i.e., 25 degrees or less).**

The procedure for sediment placement in this way is shown on Figure 2.

If the benched placement occurs within 100 feet of a spring or tributary, then fiber rolls will be placed so as to filter runoff from the graded area. Refer to Specification SC-5 in Appendix B.

4.9 Spreading Sediments in the Canal for Scouring

For sections of the canal where the levee crest is too narrow to place materials by grading, and the outboard slope is steeper than 2:1 (H:V), the sediment should be moved to a wider (or less steep outboard slope) section of levee. Another alternative is to remove organic matter from the sediment, and replace the sediments in the canal. The materials should be disturbed, and spread thinly, so that erosion will transport them to a downstream location where they can be removed in a future maintenance year, and placed in accordance with Section 4.7 or 4.8 above.

[FOR COLLABORATIVE DISCUSSION - START]

4.10 Cleaning Sand Traps

EID proposes continue the practice of periodically releasing sediments that accumulate in the "sand traps" located along the canal system. This serves the dual purpose of cleaning the canal, and of simulating natural erosional process by returning sediment bed loads to the tributaries and, ultimately, the South Fork of the American River.

[FOR COLLABORATIVE DISCUSSION - END]

4.11 Use of Former Spillways Sealed With Gunitite

There is a possibility that FERC will require formal decommissioning of these former spillways in the near future. Placing sediments, or stockpiling rock, or making burn

piles in these features is prohibited. If such work is required, this will result in double-handling of materials.

4.12 Reseeding

In late October, after all other site work is completed, a single application of seed may be applied at selected locations where vegetation or duff have been disturbed and/or sediments have been freshly placed. Refer to Appendix B, Specification EID-1 for Temporary Seeding. After placing sediments on the levee per Section 4.7 or 4.8 above, the Site Preparation or Surface Roughening sections of Specification EID-1 may be ignored. Planting will be done by hand-broadcasted seed with plant nutrients and inoculants. Prior to application, the seed mix specification shall be approved by a Forest Botanist with the U.S. Forest Service, and shall be consistent with Project 184's Noxious Weeds Control Program.

4.13 Demobilization

Following completion of each segment (including the BMP inspection, and completion of required BMPs), all construction materials will be demobilized. On the last day, all equipment and materials will be removed from the site, and the bermed storage areas will be broken down. The storage area will be hand graded to its former contours.

The only equipment and materials to be left on site are those needed for hydroseeding in late October, and ongoing maintenance of this portion of the canal system.

4.14 Storm Contingencies

Spare fiber roll and wooden stakes will be stored at the designated storage/maintenance area on each levee section. This material will be used to quickly install temporary fiber rolls in the event of an unexpected precipitation event that occurs during construction activities.

APPENDIX A

Certified Analytical Reports and Chain-of-Custody Documentation for Sediment Samples

Transmittal Letter

13-Sep-02

RECEIVED
SEP 13 2002
ENGINEERING



CARLTON
Engineering Inc.

For: Whitney Smith

El Dorado Irrigation District, Operations & Maintenance
2690 Mosquito Road
Placerville, CA 95667

Direct 530.642.4026
Fax 530.622.2528

From: Jan Renzo for Mike V.
Subject: Analytical Results
Project: 2001-140 EID Mill To Bull Tunnel WQM

These are Transmitted: For your use

Sent Via: Hand Delivery

We are sending you: Attached

Copies	Pages	Date	Description
1	7	13Sep2002	Reports

Comments:

Attached please find the Analytical Results provided by the Laboratory to Carlton Engineering, Inc.

If you have any questions please call me.

Mike V.



Carlton Engineering, Inc.
3932 Ponderosa Road, Suite 200
Shingle Springs, CA 95682

09/11/2002

Attention: Mike Vander Dussen

Reference: Analytical Results

Project Name: Sediment Removal from Canal
Project No.:
Date Received: 08/29/2002
Chain Of Custody: NO NUMBER

CLS ID No.: U0945
CLS Job No.: 850945

The following analyses were performed on the above referenced project:

<u>No. of Samples</u>	<u>Turnaround Time</u>	<u>Analysis Description</u>
4	3 Days	CAM Metals, STLC, EPA Method 6010/7000
4	3 Days	Chrome VI Analysis by IC, EPA Method 7199

These samples were received by CLS Labs in a chilled, intact state and accompanied by a valid chain of custody document.

Calibrations for analytical testing have been performed in accordance to and pass the EPA's criteria for acceptability.

Analytical results are attached to this letter. Please call if we can provide additional assistance.

Sincerely,

James Liang, Ph.D.
Laboratory Director

Analysis Report: CAM Metals, Deionized Water STLC, EPA Method 6010/7000
De-ionized Water Extraction

Client: Carlton Engineering, Inc.
3932 Ponderosa Road, Suite 200
Shingle Springs, CA 95682

Project No.:
Contact: Mike Vander Dussen
Phone: (530)677-5515

Project: Sediment Removal from Canal

Lab Contact: James Liang
Lab ID No.: U0945-1A
Job No.: 850945
COC Log No.: NO NUMBER
Batch No.: M020903A
Instrument ID: INMIX
Analyst ID: SALENAG
Matrix: SOIL

Date Sampled: 08/28/2002
Date Received: 08/29/2002
Date Extracted: 09/03/2002
Date Analyzed: 09/04/2002
Date Reported: 09/10/2002
Client ID No.: SED-1

SED-1

Analyte	CAS No.	Results (mg/L)	Rep. Limit (mg/L)	Method	Dilution (factor)
Ag (Silver)	7440224	ND	0.50	6010	1.0
As (Arsenic)	7440382	ND	0.050	7060	1.0
Ba (Barium)	7440393	ND	0.50	6010	1.0
Be (Beryllium)	7440417	ND	0.10	6010	1.0
Cd (Cadmium)	7440439	ND	0.10	6010	1.0
Co (Cobalt)	7440484	ND	0.50	6010	1.0
Cr (Chromium)	7440473	ND	0.50	6010	1.0
Cu (Copper)	7440508	ND	0.50	6010	1.0
Hg (Mercury)	7439976	ND	0.050	7471	1.0
Mo (Molybdenum)	7439987	ND	0.50	6010	1.0
Ni (Nickel)	7440020	ND	0.50	6010	1.0
Pb (Lead)	7439921	ND	0.50	6010	1.0
Sb (Antimony)	7440360	ND	0.50	6010	1.0
Se (Selenium)	7783008	ND	0.050	7740	1.0
Tl (Thallium)	7440280	ND	0.050	7841	1.0
V (Vanadium)	7440622	ND	0.50	6010	1.0
Zn (Zinc)	7440666	ND	0.50	6010	1.0

ND = Not detected at or above indicated Reporting Limit

Analysis Report: CAM Metals, Deionized Water STLC, EPA Method 6010/7000
De-ionized Water Extraction

Client: Carlton Engineering, Inc.
3932 Ponderosa Road, Suite 200
Shingle Springs, CA 95682

Project No.:
Contact: Mike Vander Dussen
Phone: (530)677-5515

Project: Sediment Removal from Canal

Date Sampled: 08/28/2002
Date Received: 08/29/2002
Date Extracted: 09/03/2002
Date Analyzed: 09/04/2002
Date Reported: 09/10/2002
Client ID No.: SED-2

Lab Contact: James Liang
Lab ID No.: U0945-2A
Job No.: 850945
COC Log No.: NO NUMBER
Batch No.: M020903A
Instrument ID: INMIX
Analyst ID: SALENAG
Matrix: SOIL

SED-2

Analyte	CAS No.	Results (mg/L)	Rep. Limit (mg/L)	Method	Dilution (factor)
Ag (Silver)	7440224	ND	0.50	6010	1.0
As (Arsenic)	7440382	ND	0.050	7060	1.0
Ba (Barium)	7440393	ND	0.50	6010	1.0
Be (Beryllium)	7440417	ND	0.10	6010	1.0
Cd (Cadmium)	7440439	ND	0.10	6010	1.0
Co (Cobalt)	7440484	ND	0.50	6010	1.0
Cr (Chromium)	7440473	ND	0.50	6010	1.0
Cu (Copper)	7440508	ND	0.50	6010	1.0
Hg (Mercury)	7439976	ND	0.050	7471	1.0
Mo (Molybdenum)	7439987	ND	0.50	6010	1.0
Ni (Nickel)	7440020	ND	0.50	6010	1.0
Pb (Lead)	7439921	ND	0.50	6010	1.0
Sb (Antimony)	7440360	ND	0.50	6010	1.0
Se (Selenium)	7783008	ND	0.050	7740	1.0
Tl (Thallium)	7440280	ND	0.050	7841	1.0
V (Vanadium)	7440622	ND	0.50	6010	1.0
Zn (Zinc)	7440666	ND	0.50	6010	1.0

ND = Not detected at or above indicated Reporting Limit

Analysis Report: CAM Metals, Deionized Water STLC, EPA Method 6010/7000
De-ionized Water Extraction

Client: Carlton Engineering, Inc.
3932 Ponderosa Road, Suite 200
Shingle Springs, CA 95682

Project No.:
Contact: Mike Vander Dussen
Phone: (530) 677-5515

Project: Sediment Removal from Canal

Lab Contact: James Liang
Lab ID No.: U0945-3A
Job No.: 850945
COC Log No.: NO NUMBER
Batch No.: M020903A
Instrument ID: INMIX
Analyst ID: SALENAG
Matrix: SOIL

Date Sampled: 08/28/2002
Date Received: 08/29/2002
Date Extracted: 09/03/2002
Date Analyzed: 09/04/2002
Date Reported: 09/10/2002
Client ID No.: SED-3

SED-3

Analyte	CAS No.	Results (mg/L)	Rep. Limit (mg/L)	Method	Dilution (factor)
Ag (Silver)	7440224	ND	0.50	6010	1.0
As (Arsenic)	7440382	ND	0.050	7060	1.0
Ba (Barium)	7440393	ND	0.50	6010	1.0
Be (Beryllium)	7440417	ND	0.10	6010	1.0
Cd (Cadmium)	7440439	ND	0.10	6010	1.0
Co (Cobalt)	7440484	ND	0.50	6010	1.0
Cr (Chromium)	7440473	ND	0.50	6010	1.0
Cu (Copper)	7440508	ND	0.50	6010	1.0
Hg (Mercury)	7439976	ND	0.050	7471	1.0
Mo (Molybdenum)	7439987	ND	0.50	6010	1.0
Ni (Nickel)	7440020	ND	0.50	6010	1.0
Pb (Lead)	7439921	ND	0.50	6010	1.0
Sb (Antimony)	7440360	ND	0.50	6010	1.0
Se (Selenium)	7783008	ND	0.050	7740	1.0
Tl (Thallium)	7440280	ND	0.050	7841	1.0
V (Vanadium)	7440622	ND	0.50	6010	1.0
Zn (Zinc)	7440666	ND	0.50	6010	1.0

ND = Not detected at or above indicated Reporting Limit

Analysis Report: CAM Metals, Deionized Water STLC, EPA Method 6010/7000
De-ionized Water Extraction

Client: Carlton Engineering, Inc.
3932 Ponderosa Road, Suite 200
Shingle Springs, CA 95682

Project No.:
Contact: Mike Vander Dussen
Phone: (530) 677-5515

Project: Sediment Removal from Canal

Lab Contact: James Liang
Lab ID No.: U0945-4A
Job No.: 850945
COC Log No.: NO NUMBER
Batch No.: M020903A
Instrument ID: INMIX
Analyst ID: SALENAG
Matrix: SOIL

Date Sampled: 08/28/2002
Date Received: 08/29/2002
Date Extracted: 09/03/2002
Date Analyzed: 09/04/2002
Date Reported: 09/10/2002
Client ID No.: SED-4

SED-4

Analyte	CAS No.	Results (mg/L)	Rep. Limit (mg/L)	Method	Dilution (factor)
Ag (Silver)	7440224	ND	0.50	6010	1.0
As (Arsenic)	7440382	ND	0.050	7060	1.0
Ba (Barium)	7440393	ND	0.50	6010	1.0
Be (Beryllium)	7440417	ND	0.10	6010	1.0
Cd (Cadmium)	7440439	ND	0.10	6010	1.0
Co (Cobalt)	7440484	ND	0.50	6010	1.0
Cr (Chromium)	7440473	ND	0.50	6010	1.0
Cu (Copper)	7440508	ND	0.50	6010	1.0
Hg (Mercury)	7439976	ND	0.050	7471	1.0
Mo (Molybdenum)	7439987	ND	0.50	6010	1.0
Ni (Nickel)	7440020	ND	0.50	6010	1.0
Pb (Lead)	7439921	ND	0.50	6010	1.0
Sb (Antimony)	7440360	ND	0.50	6010	1.0
Se (Selenium)	7783008	ND	0.050	7740	1.0
Tl (Thallium)	7440280	ND	0.050	7841	1.0
V (Vanadium)	7440622	ND	0.50	6010	1.0
Zn (Zinc)	7440666	ND	0.50	6010	1.0

ND = Not detected at or above indicated Reporting Limit

Analysis Report: Hexavalent Chromium Analysis, EPA Method 7199

Client: Carlton Engineering, Inc.
3932 Ponderosa Road, Suite 200
Shingle Springs, CA 95682

Project No.:
Contact: Mike Vander Dussen
Phone: (530) 677-5515

Project: Sediment Removal from Canal

Date Sampled: 08/28/2002
Date Received: 08/29/2002
Date Extracted: 09/03/2002
Date Analyzed: 09/04/2002
Date Reported: 09/05/2002

Lab Contact: James Liang
Lab ID No.: U0945
Job No.: 850945
COC Log No.: NO NUMBER
Batch No.: IC102020904
Instrument ID: IC001
Analyst ID: ANDORAB
Matrix: SOIL

ANALYTICAL RESULTS

Lab / Client ID Analyte	CAS No.	Results (ug/kg)	Rep. Limit (ug/kg)	Dilution (factor)
1A / SED-1 Hexavalent Chromium	N/A	ND	10	1.0
2A / SED-2 Hexavalent Chromium	N/A	ND	10	1.0
3A / SED-3 Hexavalent Chromium	N/A	ND	10	1.0
4A / SED-4 Hexavalent Chromium	N/A	ND	10	1.0

ND = Not detected at or above indicated Reporting Limit



SEQUOIA ANALYTICAL

CHAIN OF CUSTODY

CLSLABS 3249 FIVE GREENS RD. PARKER COZONA 4045

- 885 Jarvis Drive • Morgan Hill, CA 95037 • (408) 776-9600 • FAX (408) 782-6308
- 1455 McDowell Blvd, Suite D. • Petaluma, CA 94954 • (707) 792-1865 • FAX (707) 792-0342
- 819 Striker Ave., Suite 8 • Sacramento, CA 95834 • (916) 921-9600 • FAX (916) 921-0100
- 1551 Industrial Road • San Carlos, CA 94070 • (650) 232-9600 • FAX (650) 232-9612
- 404 N. Wiget Lane • Walnut Creek, CA 94598 • (925) 988-9600 • FAX (925) 988-9673

Company Name: EL DARADO IRRIGATION DISTRICT

Project: SEDIMENT REMOVAL FROM CANAL

Mailing Address: 2890 MOSAICO ROAD

Billing Address (if different): BILL VIA CARLTON ENGINEERING

City: PLACERVILLE State: CA Zip Code: 95667

Telephone: (530)

Fax #:

P.O. #:

Report To: WHIT SMITH

E-mail Address: WSMITH@EID.ORG

CC Date:

Level II (standard) Level III Level IV

Sampler: WHIT SMITH

Date / Time Results Required:

Sequoia's Work Order #

Turnaround 10-15 Working Days
 (Standard TAT)
 7 Working Days
 5 Working Days

72 Hours
 48 Hours
 24 Hours
 28 Hours

MANDATORY:
 SDWA (Drinking Water)
 CWA (Waste Water)
 RCRA (Hazardous Waste)
 Other

ANALYSES REQUESTED (Please provide method)

California WET DL
 Extraction
 CDM 17 Metals
 Retardant Cr

Comments
 Temp. (if required)
 STIC + Cr (46)

Client Sample I.D.	Date / Time Sampled	Matrix Desc.	# of Cont.	Container Type	Sequoia's Sample #	California WET DL Extraction CDM 17 Metals	Retardant Cr	Comments
1. SED-1	8/28/02 12:15 pm	Soil	1	Sequoia Bag	555	✓	✓	
2. SED-2	8/28/02 12:30 pm	Soil	1			✓	✓	
3. SED-3	8/28/02 12:43 pm	Soil	1			✓	✓	
4. SED-4	8/28/02 1:45 pm	Soil	1			✓	✓	
5.								HOLD UNTIL
6.								DIRECTION GIVEN RE
7.								EXTENSION TYPE
8.								M.V.
9.								
10.								

Relinquished By: WHIT SMITH/EID

Received By: [Signature]

Date / Time: 8/28/02, 3:28 pm

Relinquished By: [Signature]

Received By: [Signature]

Date / Time: 8-28-02 16:30

Relinquished By: [Signature]

Received By: [Signature]

Date / Time: 8/29/02 08:00

Relinquished By: [Signature]

Received By: [Signature]

Date / Time: 8/29/02 08:30

Were Samples Received in Good Condition? Yes No

Samples on Ice? Yes No

Method of Shipment: _____

Page ___ of ___

APPENDIX B
Site-Specific Erosion and Sediment Control BMPs

PERMANENT RESEEDING
EL DORADO CANAL MAINTENANCE BMP# EID-1
Rev. 5, October 3, 2002

1.0 GENERAL

This specification covers seeding for erosion control as a Best Management Practice (BMP) for areas of soil disturbed by canal maintenance activities (e.g., levee repairs, removing sediment from the canal and placing on the levee).

2.0 MATERIALS

2.1 Seed Mixes

Select plants appropriate to the season and site conditions, as recommended by the U.S. Forest Service and the Resource Conservation District.

Select plants that are consistent with FERC Project 184's Noxious Weed Control Program.

Seed shall be state-certified seed of the latest season's crop and shall be delivered in original, sealed packages bearing the producer's guaranteed analysis for percentages of mixtures, purity, germination, weed-seed content, and inert material. Labels shall conform with USDA Federal Seed Act, California Agricultural Code and other applicable seed laws, and shall be acceptable to the County Agricultural Commissioner. Wet, moldy, or otherwise damaged seed will be rejected.

U.S. Forest Service's Forest Botanist has approved the following seed mixes for use in the El Dorado National Forest:

Mix A: Dry to moderate sites, at low to mid elevations, at locations where maintenance practices do not require frequent cutting of vegetation.

Deschampsia elongata, ssp. "El Dorado Canal"	4.0 pounds per acre
Vulpia microstachys, ssp. "Sierra"	6.0 pounds per acre
Lotus purshianus, ssp. "Sierra"	7.0 pounds per acre
Bromus carinatus, var. carintus (Eldorado or Mokelumne Brome)	9.0 pounds per acre
Elymus Glaucus, ssp. "El Dorado"	8.0 pounds per acre
Elymus elymoides, ssp. "3000"	4.0 pounds per acre
Festuca rubra, ssp. "Mokelumne Fescue"	5.0 pounds per acre
TOTAL	43.0 pounds per acre

NOTE: No substitution of ecotypes will be permitted.

Mix B: Dry to moderate sites, at low to mid elevations, at locations where maintenance practices require frequent cutting of vegetation. Mix B should be applied on the levee crests and outboard slopes of the canal.

Deschampsia elongata, ssp. "El Dorado Canal"	4.0 pounds per acre
Vulpia microstachys, ssp. "Sierra"	6.0 pounds per acre
Lotus purshianus, ssp. "Sierra"	7.0 pounds per acre
Elymus elymoides, ssp. "3000"	6.0 pounds per acre
Festuca rubra, ssp. "Mokelumne Fescue"	6.0 pounds per acre
Poa secunda juncafolia, ssp. "Tahoe"	6.0 pounds per acre
Achillea millefolium, ssp. "Sierra"	2.0 pounds per acre
TOTAL	37.0 pounds per acre

NOTE: No substitution of ecotypes will be permitted.

The seed mixes listed above is available at Conserva-Seed, contact Scott Stewart at (916) 775-1676.

The seeding rates are based on a minimum acceptable pure live seed (PLS) of 80%. When PLS is below 80%, adjust application rates accordingly.

2.2.1 Inoculant

In locations where soil conditions are poor, previously vegetated with annual, noxious weed species or where vegetation must be reestablished because of proximity to sensitive water courses, the seed shall be embedded in a micronutrient/ mycorrhiza inoculant mixture to facilitate symbiosis and speed seed growth. These seedings shall be coated at a density of 10,000 or more living propagules (either spores or mycelia) Glomus Intraradices per lb of coating. The U.S. Forest Service's Forest Botanist has approved the use of SOW-EZ™ seed processing as a micronutrient/ mycorrhiza source for the approved seed mixes in El Dorado National Forest. SOW-EZ will be applied to seed at a mass ratio of 3 parts nutrient/mycorrhizal coating to 1 part of seed input. The embedded seeds shall be less than 1 year old.

The SOW-EZ process is available from ConservaSeed: contact Scott Stewart at (916) 775-1676.

2.3 Fertilizer

Fertilizer shall be slow-release, organic product, commercial grade, granular free flowing, uniform in composition, delivered in fully-labeled sealed containers, and shall conform to applicable state and federal regulations. Fertilizer shall have the manufacture's guaranteed statement of analysis.

The U.S. Forest Service-approved fertilizer product is BIOSOL Mix 7-2-3. For Seed Mix A, BIOSOL Mix 7-2-3 will be applied. BIOSOL Mix 7-2-3 will be applied with and application rate of 1000 lbs/ac, reflecting a Nitrogen application rate of 70 lbs/ac and a Phosphorus application rate of 20 lbs/ac.

For Seed Mix B, low-Phosphorous BIOSOL Mix 6-1-3 will be applied. BIOSOL Mix 6-1-3 will be applied with and application rate of 500 lbs/ac, reflecting a Nitrogen application rate of 30 lbs/ac and a Phosphorus application rate of 5 lbs/ac.

The BIOSOL fertilizer mix is available from Rocky Mountain Bio Products, (970) 926-1025.

3.0 EXECUTION

3.1 Timing

Seeding is to be completed between September 15 and October 15, and prior to the onset of the rainy season.

3.2 Site Preparation

Grade as needed and feasible to permit the use of equipment for seedbed preparation.

Install needed erosion control practices, such as silt screens and fiber rolls prior to seeding. Divert concentrated flows away from seeded areas.

Soil tests should be done to determine the nutrient pH content of soil. USFS soil scientists estimate the soil pH along the canal to range between 5.5 and 6.0, which is typical for Sierran forest soils. The grasses and one forb in the seed mixes A and B are from Eldorado National Forest or other Sierra Nevada collection sites, and are expected to be adapted to a pH range of 5.5 to 6.0.

Depending on the results of soil tests, soil management may be necessary to adjust the pH to between 5.5 to 6.0 (for most conditions). All lime, fertilizer and other soil amendments shall be applied following sound soil management practices.

3.3 Surface Roughening

If the area has been recently loosened or disturbed, no further roughening is required. When the area is compacted, crusted or hardened, the soil shall be loosened with dicing, raking or harrowing. Tracking with bulldozer cleats is very effective on sandy soils.

Hydro seeding and hydraulic planting generally require less seedbed preparation. Do not hydro seed Sow-EZ pelleted seed. Distribute by acceptable dry broadcast methods uniformly throughout target area as per above in sec 2.2.1

Generally, slopes steeper than 2:1 cannot have good seedbed preparation with equipment, and will sometimes require hydraulic planting techniques.

Seed to soil contact is the key to good germination. Prepare a 3 – 5 inch deep seedbed, with the top 3 – 4 inches consisting of topsoil. Note that the earth bed upon which the topsoil is to be placed should be at the required grade.

The seedbed should be firm but not compact. The top 3 inches of soil should be loose, moist and free of large clods and stones. For most applications, all stones larger than 2 inches in diameter, roots, litter and any foreign matter should be raked and removed.

3.4 Fertilizing

Apply fertilizer if required. Seed and fertilizer should be incorporated into the soil by raking or chain dragging, or otherwise floated, then lightly compacted to provide good fertilizer-soil contact.

Fertilizer shall be slow-release, organic product, commercial grade, granular free flowing, uniform in composition, delivered in fully-labeled sealed containers, and shall conform to applicable state and federal regulations. Fertilizer shall bear the manufacture's guaranteed statement of analysis.

For Seed Mix A, BIOSOL Mix 7-2-3 will be applied at an application rate of 1000 lbs/ac.

For Seed Mix B, low-Phosphorous BIOSOL Mix 6-1-3 will be applied with an application rate of 500 lbs/ac

3.5 Seeding

Seed (as seed or pelletized SOW-EZ inoculant) should be applied as soon after seedbed preparation and fertilizing as possible, when the soil is loose and moist.

Always apply seed or inoculant before mulch.

Apply seed or inoculant/seed mixture using hand broadcasting, calibrated spreaders, cyclone seeders, mechanical drills, or hydro seeders (only for seed) so the seed is applied uniformly on the site. Do not hydro seed SOW-EZ pelleted seed.

After broadcasting, use raking, chain dragging, double ring rolling, or pressing into soil surface using a light flat-roller or equivalent.

3.6 Mulching

Straw mulch, erosion control blankets or mulch and tackifiers/soil binders should be applied over the seeded areas.

Straw will be weed-free rice straw, applied at 1,400 lbs/AC. Straw will be crimped into soil after placement.

3.7 Inspection and Maintenance

Newly-seeded areas need to be inspected frequently to ensure the grass is growing. Areas which fail to establish cover adequate to prevent sheet and rill erosion will be re-seeded as soon as such areas are identified. Spot seeding can be done on small areas to fill in bare spots where grass did not grow properly.

If seeded area is damaged due to concentrated runoff, additional practices may be needed.

Temporary vegetated areas will be maintained until permanent vegetation or other erosion control can be established.

Cut or mow once per year to a height of 6 to 8 inches. Cut or mow at annual seed head emergence when annuals are in full bloom but have yet to re-produce viable seeds (i.e., are in the gel stage, and have just begun to produce pollen). For the El Dorado Canal, this will typically be in May or early June.

Additional cutting or mowing at other times of the year is acceptable, as required.

END

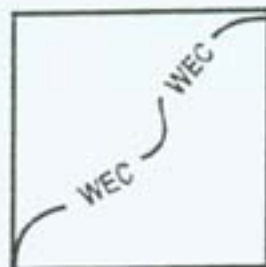
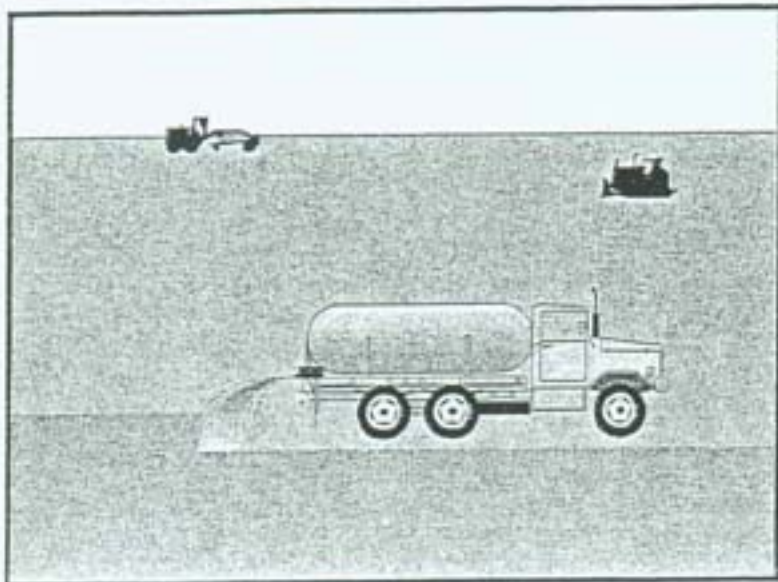

BMP Objectives

- Soil Stabilization
- Sediment Control
- Tracking Control
- Wind Erosion Control
- Non-Storm Water Management
- Materials and Waste Management

Definition and Purpose Wind erosion control consists of applying water or other dust palliatives as necessary to prevent or alleviate dust nuisance. Dust control shall be applied in accordance with Caltrans standard practices. Covering of small stockpiles or areas is an alternative to applying water or other dust palliatives.

Appropriate Applications This practice is implemented on all exposed soils subject to wind erosion.

Limitations Effectiveness depends on soil, temperature, humidity and wind velocity.

- Standards and Specifications**
- Water shall be applied by means of pressure-type distributors or pipelines equipped with a spray system or hoses and nozzles that will ensure even distribution.
 - All distribution equipment shall be equipped with a positive means of shutoff.
 - Unless water is applied by means of pipelines, at least one mobile unit shall be available at all times to apply water or dust palliative to the project.
 - If reclaimed waste water is used, the sources and discharge must meet California Department of Health Services water reclamation criteria and the Regional Water Quality Control Board requirements. Non-potable water shall not be conveyed in tanks or drain pipes that will be used to convey potable water and there shall be no connection between potable and non-potable supplies. Non-potable tanks, pipes and other conveyances shall be marked "NON-POTABLE WATER - DO NOT DRINK."
 - Materials applied as temporary soil stabilizers and soil binders will also provide wind erosion control benefits.

Maintenance and Inspection

- Check areas protected to ensure coverage.
- Implement requirements of Section 10 of the Caltrans Standard Specifications as appropriate.

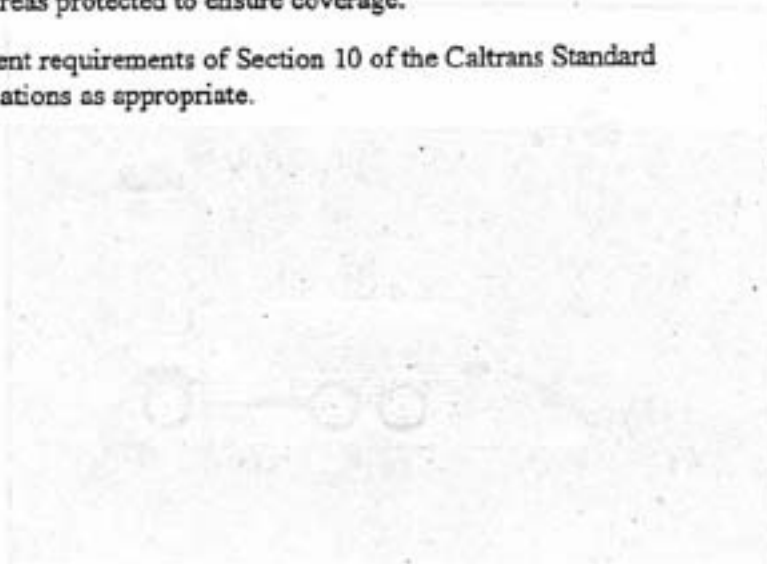
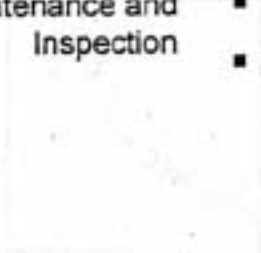

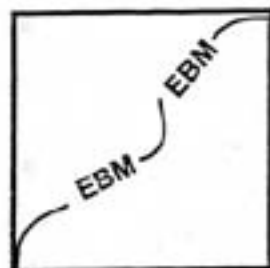
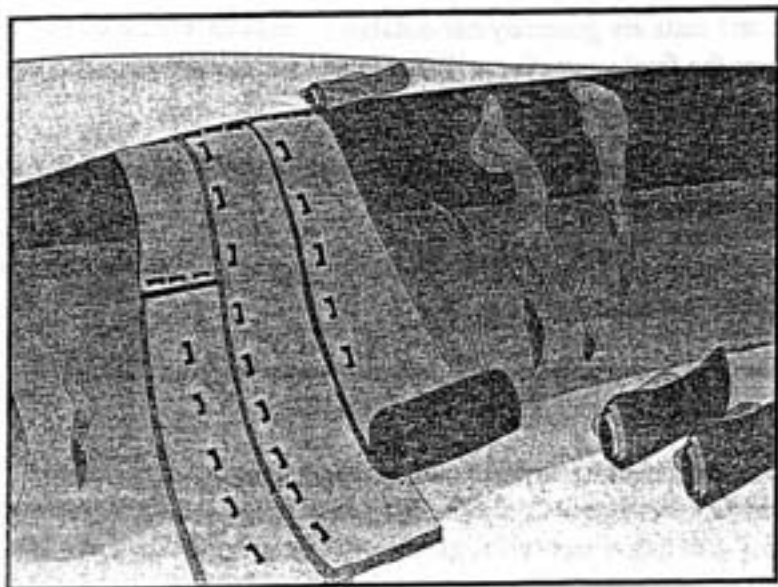

BMP Objectives

- Soil Stabilization
- Sediment Control
- Tracking Control
- Wind Erosion Control
- Non-Storm Water Management
- Materials and Waste Management

Definition and Purpose

This Best Management Practice (BMP) involves the placement of geotextiles, plastic covers, or erosion control blankets/mats to stabilize disturbed soil areas and protect soils from erosion by wind or water. This is one of five temporary soil stabilization alternatives to consider.

Appropriate Applications

These measures are used when disturbed soils may be particularly difficult to stabilize, including the following situations:

- Steep slopes, generally steeper than 1:3 (V:H).
- Slopes where the erosion hazard is high.
- Slopes and disturbed soils where mulch must be anchored
- Disturbed areas where plants are slow to develop adequate protective cover.
- Channels with flows exceeding 1.0 m/s (3.3 ft/s).
- Channels intended to be vegetated.
- Stockpiles
- Slopes adjacent to water bodies of Environmentally Sensitive Areas (ESAs).

Limitations

- Blankets and mats are more expensive than other erosion control measures, due to labor and material costs. This usually limits their application to areas inaccessible to hydraulic equipment, or where other measures are not applicable, such as channels.

Geotextiles, Plastic Covers and Erosion Control Blankets/Mats

- Blankets and mats are generally not suitable for excessively rocky sites, or areas where the final vegetation will be mowed (since staples and netting can catch in mowers).
- Blankets and mats must be removed and disposed of prior to application of permanent soil stabilization measures.
- Plastic sheeting is easily vandalized, easily torn, photodegradable, and must be disposed of at a landfill.
- Plastic results in 100 percent runoff, which may cause serious erosion problems in the areas receiving the increased flow.
- The use of plastic shall be limited to covering stockpiles, or very small graded areas for short periods of time (such as through one imminent storm event), until alternative measures, such as seeding and mulching, may be installed.

Standards and Specifications

Material Selection

There are many types of erosion control blankets and mats, and selection of the appropriate type should be based on the specific type of application and site conditions. Selection(s) made by the Contractor must be approved by the Resident Engineer (RE). The following criteria shall be considered in selection of the appropriate material:

- Cost
 - Material cost
 - Preparation cost
 - Installation cost
 - Add-ons
- Effectiveness
 - Reduction of erosion
 - Reduction of flow velocity
 - Reduction of runoff
- Acceptability
 - Environmental compatibility
 - Institutional/regulatory acceptability
 - Visual impact



- Vegetation Enhancement
 - Native plant compatibility
 - Moisture retention
 - Temperature modification
 - Open space/coverage

- Installation
 - Durability
 - Longevity
 - Ease of installation
 - Safety

- Operation and Maintenance
 - Maintenance frequency

Geotextiles

- Material shall be a woven polypropylene fabric with minimum thickness of 15 mm, minimum width of 3.7 m and shall have minimum tensile strength of 0.67 kN (warp) 0.36 kN (fill) in conformance with the requirements in ASTM Designation: D 4632. The permittivity of the fabric shall be approximately 0.07 sec^{-1} in conformance with the requirements in ASTM Designation: D4491. The fabric shall have an ultraviolet (UV) stability of 70 percent in conformance with the requirements in ASTM designation: D4355. Geotextile blankets shall be secured in place with wire staples or sandbags and by keying into tops of slopes to prevent infiltration of surface waters under Geotextile.

- Geotextiles may be reused if, in the opinion of the RE, they are suitable for the use intended.

Plastic Covers

- Temporary soil stabilization (Type plastic cover) material shall be polyethylene sheeting and shall have a minimum thickness of 6 mils. Plastic covers shall be anchored by sandbags placed no more than 3 m (10 ft) apart and by keying into the tops of slopes to prevent infiltration of surface waters under the plastic. All seams shall be taped or weighted down their entire length, and there shall be at least a 300 mm (12 in) to 600 mm (24 in) overlap of all seams.

- Plastic covers may be reused if, in the opinion of the RE, they are suitable for the use intended.

Erosion Control Blankets/Mats

- Erosion control blankets/mats shall be either straw, coconut, straw/coconut or Excelsior blanket, in accordance with the project Special Provisions, SSP 07-390.

Site Preparation

- Proper site preparation is essential to ensure complete contact of the blanket or matting with the soil.
- Grade and shape the area of installation.
- Remove all rocks, clods, vegetation or other obstructions so that the installed blankets or mats will have complete, direct contact with the soil.
- Prepare seedbed by loosening 50 mm (2 in) to 75 mm (3 in) of topsoil.

Seeding

Seed the area before blanket installation for erosion control and revegetation. Seeding after mat installation is often specified for turf reinforcement application. When seeding prior to blanket installation, all check slots and other areas disturbed during installation must be re-seeded. Where soil filling is specified, seed the matting and the entire disturbed area after installation and prior to filling the mat with soil.

Anchoring

- U-shaped wire staples, metal geotextile stake pins or triangular wooden stakes can be used to anchor mats and blankets to the ground surface.
- Staples shall be made of 3.05 mm steel wire and shall be U-shaped with 200-mm legs and 50-mm crown. Wire staples shall be minimum of 11 gauge.
- Metal stake pins shall be 5 mm (0.188 in) diameter steel with a 40 mm (1.5 in) steel washer at the head of the pin.
- Wire staples and metal stakes shall be driven flush to the soil surface.
- All anchors shall be 150 mm (6 in) to 450 mm (18 in) long and have sufficient ground penetration to resist pullout. Longer anchors may be required for loose soils.

Installation on Slopes

Always consult the manufacturer's recommendations for installation. In general, these will be as follows:

- Begin at the top of the slope and anchor the blanket in a 150 mm (6 in) deep by 150 mm (6 in) wide trench. Backfill trench and tamp earth firmly.
- Unroll blanket downslope in the direction of water flow.
- Overlap the edges of adjacent parallel rolls 50 mm (2 in) to 75 mm (3 in) and staple every 1 m (3 ft).
- When blankets must be spliced, place blankets end over end (shingle style) with 150 mm (6 in) overlap. Staple through overlapped area, approximately 300 mm (12 in) apart.
- Lay blankets loosely and maintain direct contact with the soil. Do not stretch.
- Staple blankets sufficiently to anchor blanket and maintain contact with the soil. Staples shall be placed down the center and staggered with the staples placed along the edges. Steep slopes, 1:1 (V:H) to 1:2 (V:H), require a minimum of 2 staples/m² (2 staples/yd²). Moderate slopes, 1:2 (V:H) to 1:3 (V:H), require a minimum of 1½ staples/m² (1½ staples/yd²), placing 1 staple/m (1 staple/yc) on centers. Gentle slopes require a minimum of 1 staple/m² (1 staple/yc).

Installation in Channels

Always consult the manufacturer's recommendations for installation. In general, these will be as follows:

- Dig initial anchor trench 300 mm (12 in) deep and 150 mm (6 in) wide across the channel at the lower end of the project area.
- Excavate intermittent check slots, 150 mm (6 in) deep and 150 mm (6 in) wide across the channel at 8 m to 10 m (25 ft to 30 ft) intervals along the channel's.
- Cut longitudinal channel anchor slots 100 mm (4 in) deep and 100 mm (4 in) wide along each side of the installation to bury edges of matting, whenever possible extend matting 50 mm (2 in) to 75 mm (3 in) above the crest of the channel side slopes.

Geotextiles, Plastic Covers and Erosion Control Blankets/Mats

- Beginning at the downstream end and in the center of the channel, place the initial end of the first roll in the anchor trench and secure with fastening devices at 300 mm (12 in) intervals. Note: matting will initially be upside down in anchor trench.
- In the same manner, position adjacent rolls in anchor trench, overlapping the preceding roll a minimum of 75 mm (3 in).
- Secure these initial ends of mats with anchors at 300 mm (12 in) intervals, backfill and compact soil.
- Unroll center strip of matting upstream. Stop at next check slot or terminal anchor trench. Unroll adjacent mats upstream in similar fashion, maintaining a 75 mm (3 in) overlap.
- Fold and secure all rolls of matting snugly into all transverse check slots. Lay mat in the bottom of the slot then fold back against itself. Anchor through both layers of mat at 300 mm (12 in) intervals, then backfill and compact soil. Continue rolling all mat widths upstream to the next check slot or terminal anchor trench.
- Alternate method for non-critical installations: Place two rows of anchors on 150 mm (6 in) centers at 8 m (25 ft) to 10 m (30 ft) intervals in lieu of excavated check slots.
- Shingle-lap spliced ends by a minimum of 300 mm (12 in) apart on 300 mm (12 in) intervals.
- Place edges of outside mats in previously excavated longitudinal slots, anchor using prescribed staple pattern, backfill and compact soil.
- Anchor, fill and compact upstream end of mat in a 300 mm (12 in) by 150 mm (6 in) terminal trench.
- Secure mat to ground surface using U-shaped wire staples, geotextile pins, or wooden stakes.
- Seed and fill turf reinforcement matting with soil, if specified.

Soil Filling (if specified for turf reinforcement)

- Always consult the manufacturer's recommendations for installation.
- Do not drive tracked or heavy equipment over mat.

Geotextiles, Plastic Covers and Erosion Control Blankets/Mats

SS-7

- Avoid any traffic over matting if loose or wet soil conditions exist.
- Use shovels, rakes or brooms for fine grading and touch up.
- Smooth out soil filling; just exposing top netting of mat.

Temporary Soil Stabilization Removal

- When no longer required for the work, temporary soil stabilization shall become the property of the Contractor. Temporary soil stabilization removed from the site of the work shall be disposed of outside the highway right of way in conformance with the provisions in Section 7-1.13 of the Standard Specifications.

Maintenance and Inspection

Areas treated with temporary soil stabilization shall be inspected as specified in the special provisions. Areas treated with temporary soil stabilization shall be maintained to provide adequate erosion control. Temporary soil stabilization shall be reapplied or replaced on exposed soils when greater than 10 percent of the previously treated area becomes exposed or exhibits visible erosion.

- All blankets and mats shall be inspected periodically after installation.
- Installation shall be inspected after significant rain storms to check for erosion and undermining. Any failures shall be repaired immediately.
- If washout or breakage occurs, re-install the material after repairing the damage to the slope or channel.

Geotextiles, Plastic Covers and Erosion Control Blankets/Mats

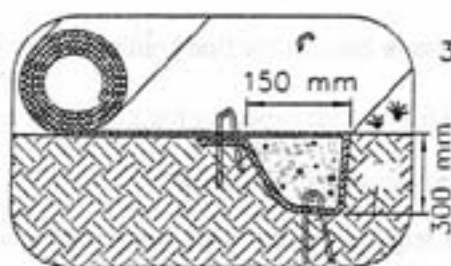

INITIAL CHANNEL ANCHOR TRENCH
NTS

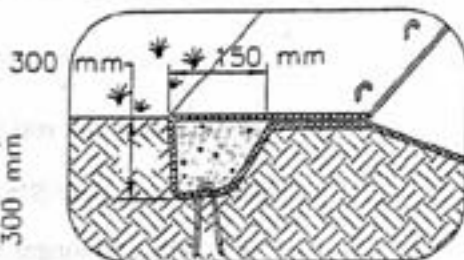

TERMINAL SLOPE AND CHANNEL
ANCHOR TRENCH
NTS

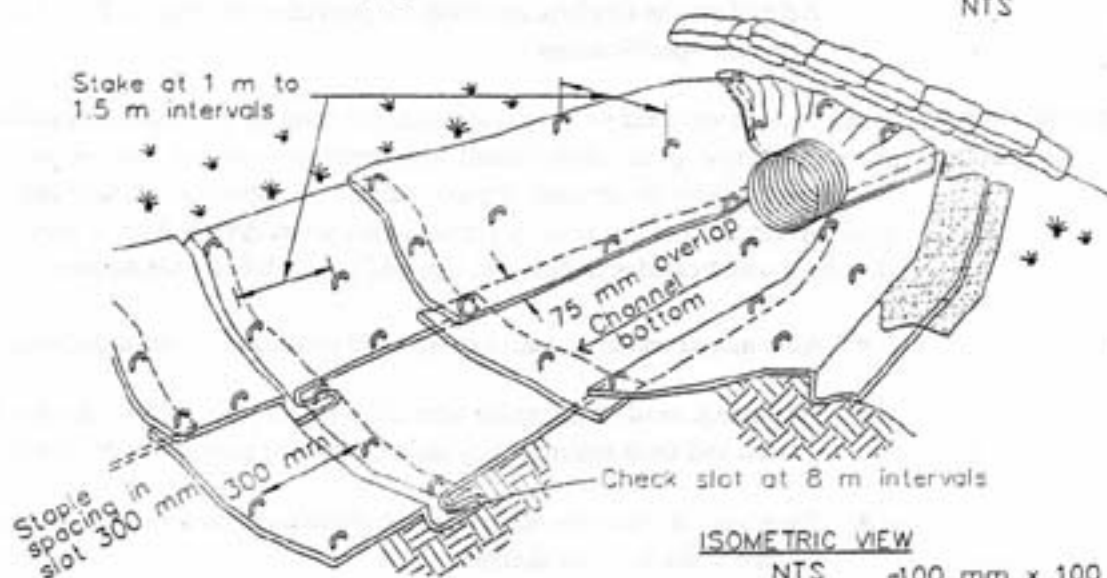

ISOMETRIC VIEW
NTS

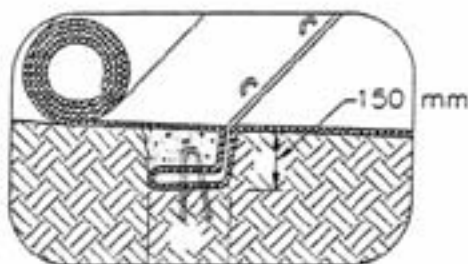

INTERMITTENT CHECK SLOT
NTS

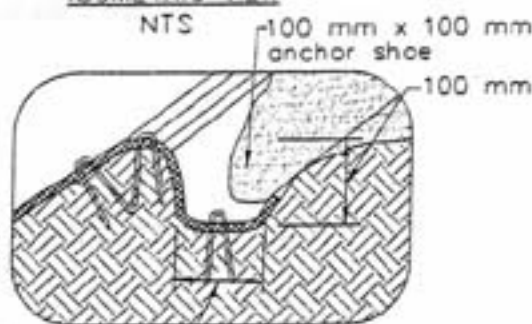

LONGITUDINAL ANCHOR TRENCH
NTS

NOTES:

1. Check slots to be constructed per manufacturers specifications.
2. Staking or stapling layout per manufacturers specifications.
3. Install per manufacturer's recommendations

Geotextiles, Plastic Covers and Erosion Control Blankets/Mats

SS-7

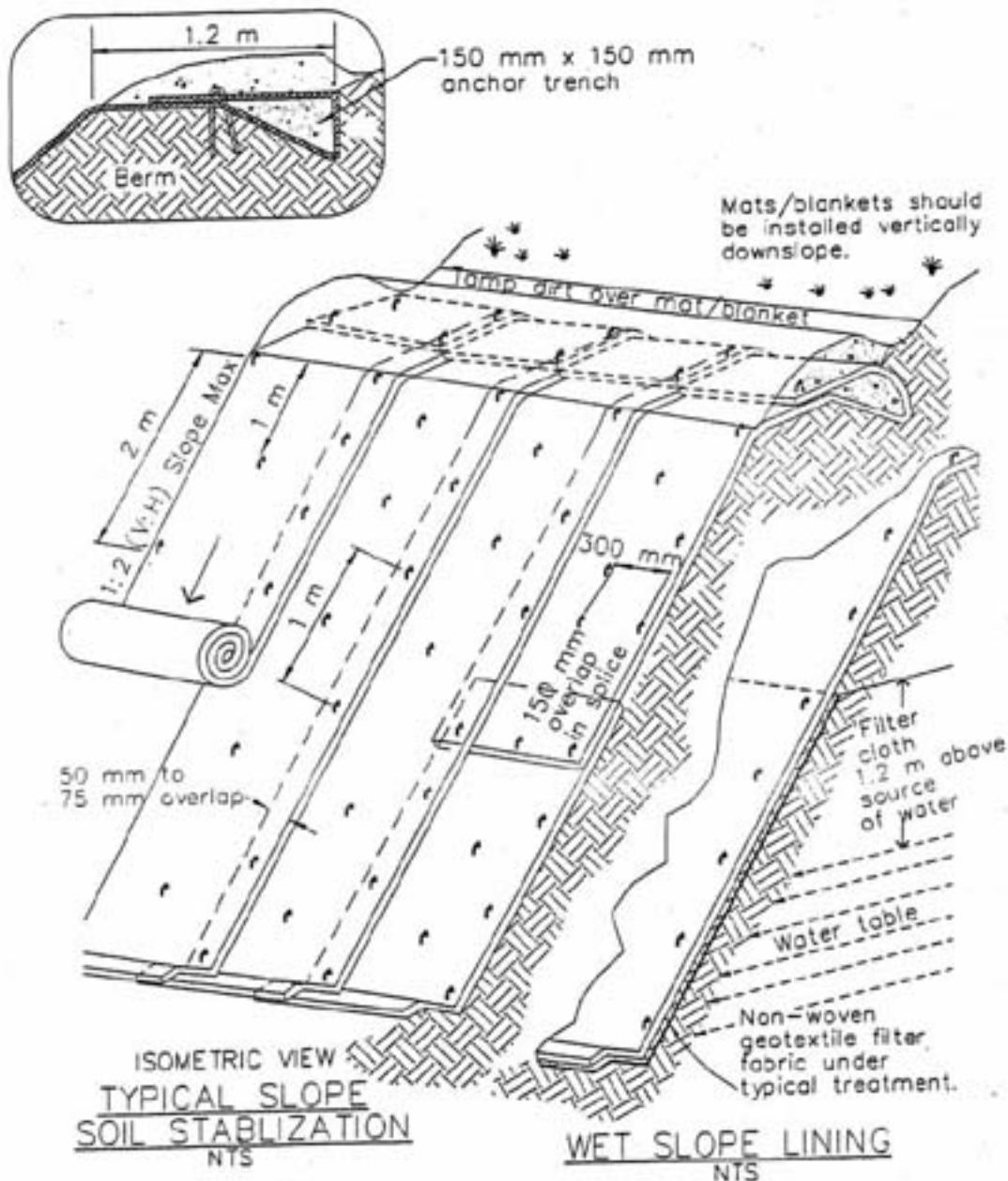

NOTES:

1. Slope surface shall be free of rocks, clods, sticks and grass. Mats/blankets shall have good soil contact.
2. Lay blankets loosely and stake or staple to maintain direct contact with the soil. Do not stretch.
3. Install per manufacturer's recommendations



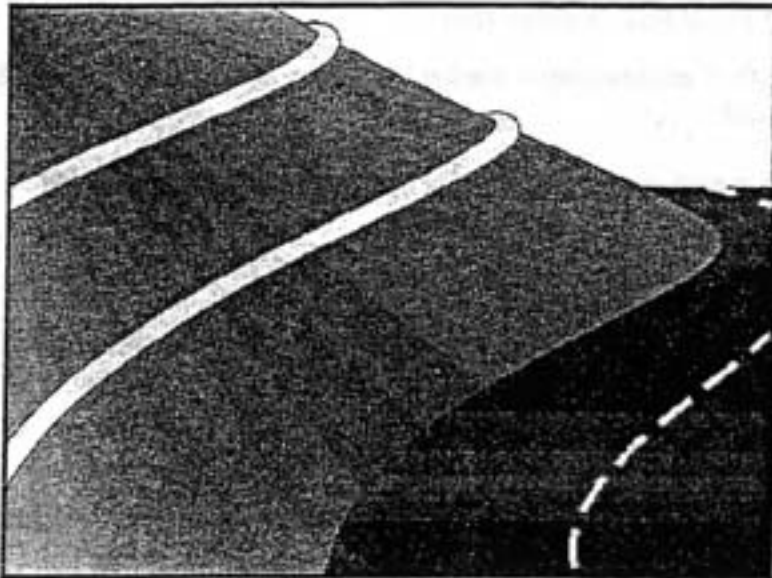

- BMP Objectives**
- Soil Stabilization
 - Sediment Control
 - Tracking Control
 - Wind Erosion Control
 - Non-Storm Water Management
 - Materials and Waste Management

Definition and Purpose A fiber roll consists of straw, flax, or other similar materials that are rolled and bound into a tight tubular roll and placed on the face of slopes at regular intervals to intercept runoff, reduce its flow velocity, release the runoff as sheet flow, and provide some removal of sediment from the runoff.

- Appropriate Applications**
- May be used along the top, face, and at grade breaks of exposed and erodible slopes to shorten slope length and spread runoff as sheet flow.
 - Fiber rolls may be used as check dams if approved by the Resident Engineer (RE).
 - This BMP may be implemented on a project-by-project basis with other BMPs when determined necessary and feasible by the RE.

- Limitations**
- Is a relatively new sediment control/soil stabilization technology. Effectiveness and capabilities in the field are not completely known.
 - Although fiber rolls provide some sediment removal, this BMP is not to be used in place of a linear sediment barrier (i.e., a silt fence, sandbag barrier, or straw bale barrier).

Standards and Specifications *Fiber Roll Materials*

- Fiber rolls shall be either:
 - (1) prefabricated rolls; or,
 - (2) rolled tubes of erosion control blanket.

Assembly of Field Rolled Fiber Roll

- Roll length of erosion control blanket into a tube of minimum 200 mm (8 in) diameter.
- Bind roll at each end and every 1.2 m (4 ft) along length of roll with jute-type twine.

Installation

- Locate fiber rolls on level contours spaced 2.4 to 6.0 m (8 to 20 ft) along the face of slope, or as required by the RE.
- Stake fiber rolls into a 50 to 100 mm (2 to 4 in) trench.
- Drive stakes at the end of each fiber roll and spaced 1.2 m (4 ft) maximum on center.
- Use wood stakes with a nominal classification of 19 by 19 mm (3/4 by 3/4 in), and minimum length of 600mm (24 in).
- If more than one fiber roll is placed in a row, the rolls shall be butted; not overlapped.

Removal

- Fiber rolls are typically left in place.
- If fiber rolls are removed, collect and dispose of sediment accumulation, and fill and compact holes, trenches, depressions or any other ground disturbance to blend with adjacent ground.

Maintenance and Inspection

- Repair or replace split, torn, unraveling, or slumping fiber rolls.
- Inspect fiber rolls when rain is forecast. Perform maintenance as needed or as required by the RE.
- Inspect fiber rolls following rainfall events and a least daily during prolonged rainfall. Perform maintenance as needed or as required by the RE.

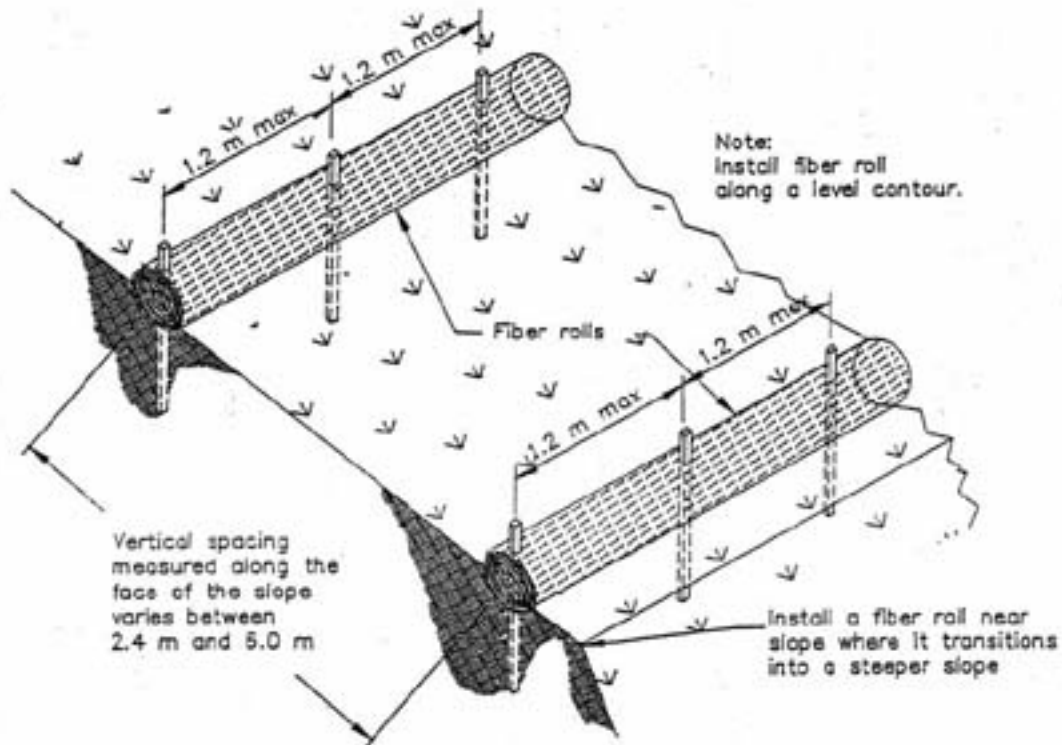

TYPICAL FIBER ROLL INSTALLATION

N.T.S.

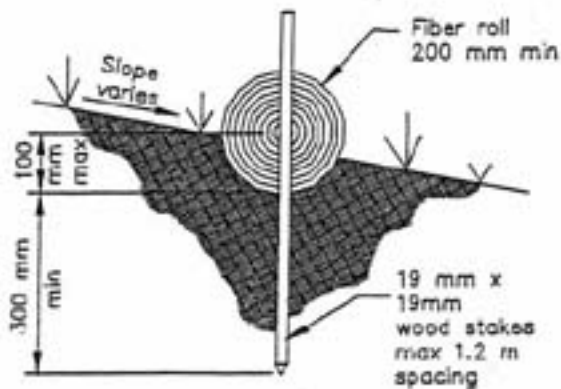

ENTRENCHMENT DETAIL

N.T.S.